

DUO Collection

design by
Roberto Lazzeroni

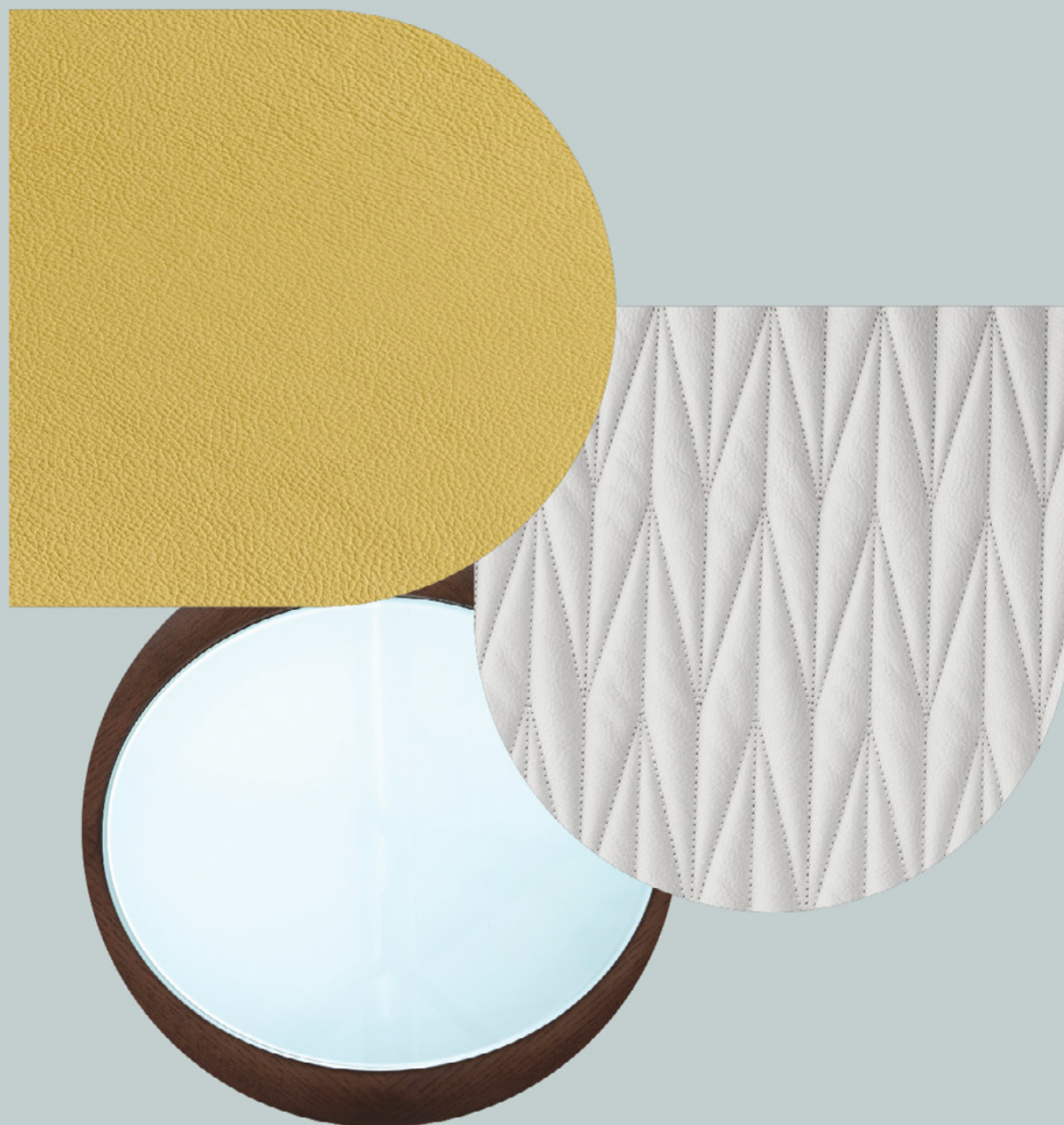

CECCOTTICOLLEZIONI



CECCOTTICOLLEZIONI



DUO Collection

Main Index

144	DUO Bed	82	DUO Low Table
148	DUO Bedside Table	130	DUO Mirror
72	DUO Bench	88	DUO Pedestal Table
104	DUO Bookcase	134	DUO Rug
108	DUO Cabinet	138	DUO Screen
76	DUO Chair/Small armchair	62	DUO Sofa
152	DUO Chest of Drawers	92	DUO Table
116	DUO Console	142	DUO Triptych Mirror
120	DUO Floor Mirror	96	DUO Trolley
122	DUO Lamp	126	DUO Valet Stand
56	DUO Lounge	100	DUO Vanity
		157	Translations and Technical Drawings

Armchairs, Sofas



56 DUO Lounge



62 DUO Sofa

Bookcases, Storage Units



104 DUO Bookcase



108 DUO Cabinet



116 DUO Console

Chairs, Small Armchairs, Stools



72 DUO Bench



76 DUO Chair/Small armchair

Complementary Units, Accessories



120 DUO Floor Mirror



122 DUO Lamp



126 DUO Valet Stand



130 DUO Mirror

Tables, Small Tables, Desks



80 DUO Low Table



88 DUO Pedestal Table



92 DUO Table



96 DUO Trolley



134 Duo Rug



138 DUO Screen

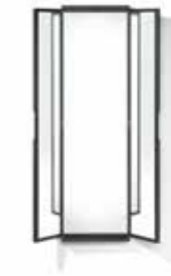

142 DUO Triptych Mirror

Beds and Night Complementary Units



144 DUO Bed



148 DUO Bedside Table



152 DUO Chest of Drawers



100 DUO Vanity

DUO Collection

The collection designed by Roberto Lazzeroni is the first chapter of the collaboration between the two Made in Italy excellences. The design synergy between Poltrona Frau and Ceccotti Collezioni is expressed by a range of products that encapsulates both their rich heritage and a shared creative vision toward the future.

The DUO Collection takes its name from the concept of union of two separate elements. Not simply the sum two individuals, it represents "two experiences that generate a common thought." In Duo, individuality does not lose its identity; it is enhanced in the shared creative act.

The collection develops from two seemingly opposite concepts, Memory and Innovation. The two paths, one enhancing the past and one projected to new contemporary horizons, find their meeting point in a line of timeless, universal objects of minimalist elegance.

The atmosphere that inspired the development of the DUO Collection is the Italian Dolce Vita, evocative of a carefree lifestyle that is naturally elegant and inclined to the pleasure of social interaction. The products are designed to furnish a romantic and cozy living room, inspired by the Italian "salotti" of the fifties, a period of rebirth and post-war intellectual and creative buzz. Silhouettes with a retro flair that capture the zeitgeist of the past, yet perfectly adaptable to contemporary contexts thanks to the versatile soft shapes, accurate proportions, and high-quality material finishes.









↑ DUO Trolley, bronzed glass upper top, coloured glass NCS S 3005Y50R Tortora lower top, with ash in a Wenge stain structure

↗ DUO Console, top coloured glass NCS S 4005G20Y Celadon with ash in a Wenge stain structure







↖ ↑ DUO High Cabinet, 2 doors in ebony with ash in a Wenge stain structure



↑ DUO Low Table, ash in a Wenge stain structure.
DUO Low Table, H 50 with coloured glass top
NCS S5040Y80R Rosso Cina

↑ ↗ DUO Low Table, ash in a Wenge stain structure.
DUO Low Table, H 36 with coloured glass top
NCS S3005Y50R Tortora





↑ DUO Bookcase, top in coloured glass NCS S 3502Y Grigio with ash in a Wenge stain structure

↗ DUO Lounge, armchair upholstered in Ziggy fabric col. Red Onion with ash in a Wenge stain structure



↑ DUO Pedestal Table, top in Calacatta marble with ash in a Wenge stain structure

↑ DUO Lamp, ash in a Wenge stain structure



↑ DUO Bench, Pelle Frau® Velvety Gray Salt with ash in a Wenge stain structure

↑ DUO Bench, fabric Ziggy Red Onion with ash in a Wenge stain structure



↑ DUO Lounge, armchair Pelle Frau® SC 177 Limo with ash in a Wenge stain structure

↑ DUO Lounge, armchair upholstered in Mollis fabric col.1A Milk with ash in a Wenge stain structure





↖ ↑ DUO Sofa, Pelle Frau® Velvety Gray Salt
DUO Small table, ash in a Wenge stain structure





↑ DUO Low Cabinet, doors in inlaid maple with ash in a Wenge stain structure
DUO Mirror 113×113, ash in a Wenge stain

↗ DUO Lounge, Pelle Frau® Velvety Lavender with ash in a Wenge stain structure; DUO Sofa, Pelle Frau® Velvety Gray Salt; DUO Low table, top in Total Calacatta marble with ash in a Wenge stain structure; DUO Pedestal Table, coloured glass with ash in a Wenge stain structure

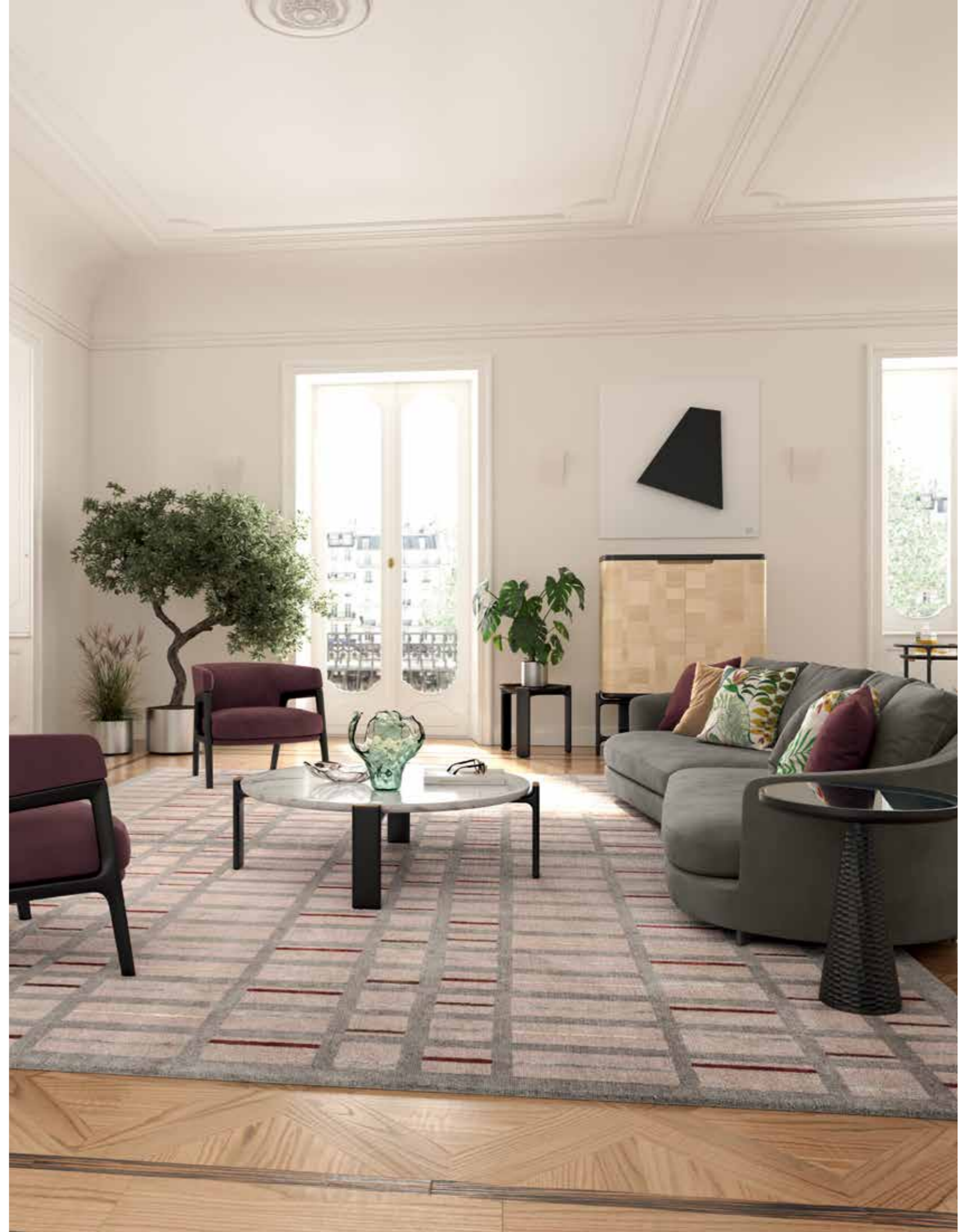





↖ ↑ DUO Chair, Pelle Frau® SC 32 Caolino with ash in a Wenge stain structure
DUO Table 250×110 cm, Calacatta marble with ash in a Wenge stain structure



↑ DUO High Cabinet, doors in inlaid maple with ash in a Wenge stain structure



↑ DUO Trolley, bronzed glass upper top, Calacatta marble lower top, with ash in a Wenge stain structure



↑ ↗ DUO Bench, Pelle Frau® Nest Pietra di Sole with ash in a Wenge stain structure







↖ ↑ DUO Table Ø180, Calacatta marble with ash
in a Wenge stain structure
DUO Small Armchair, Pelle Frau® SC 136 Ginger
Bread with ash in a Wenge stain structure



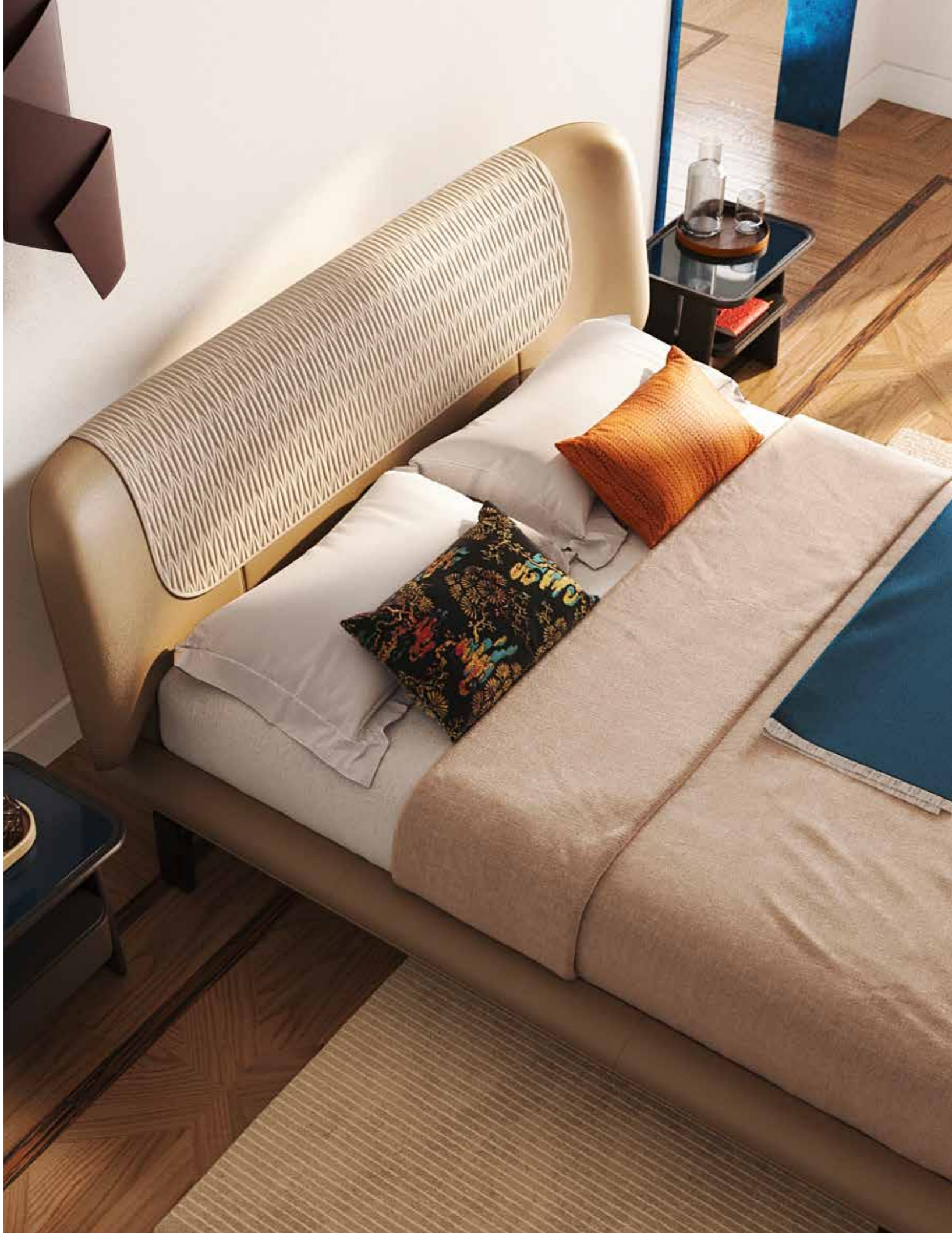

↙ DUO Bed, Pelle Frau® SC 33 Travertino with quilt in Pelle Frau® SC 32 Caolino and feet in a Wenge stain structure

↑ DUO Bedside Table with shelf, top in colored glass NCS S8010R90B with ash in a Moka stain structure



↑ DUO Bedside Table with drawer, top in colored glass NCS S8010R90B with ash in a Wenge stain structure drawer bottom in leather Pelle Frau® SC 33 Travertino.

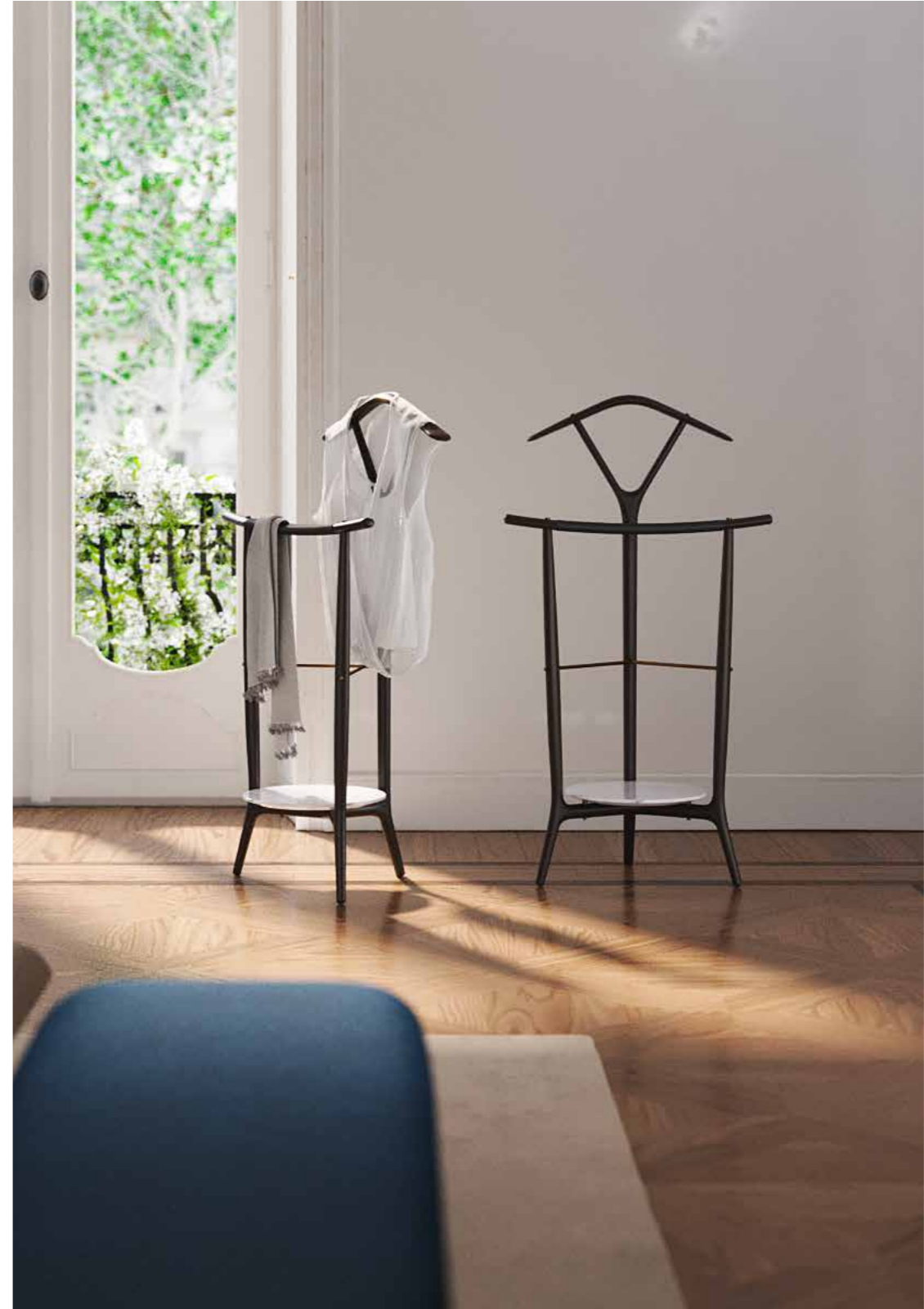

↑ DUO Valet Stand total marble Calacatta with ash in a Wenge stain structure and leather cord 201 Testa di Moro



↑ DUO Lamp in ash in a Wenge stain structure
DUO Chest of Drawers, top in Calacatta,
external parts in ebony, sliding tray in Pelle
Frau® SC 34 Maggese with ash in a Wenge
stain structure

↗ DUO Triptych Mirror in ash in a Wenge stain structure

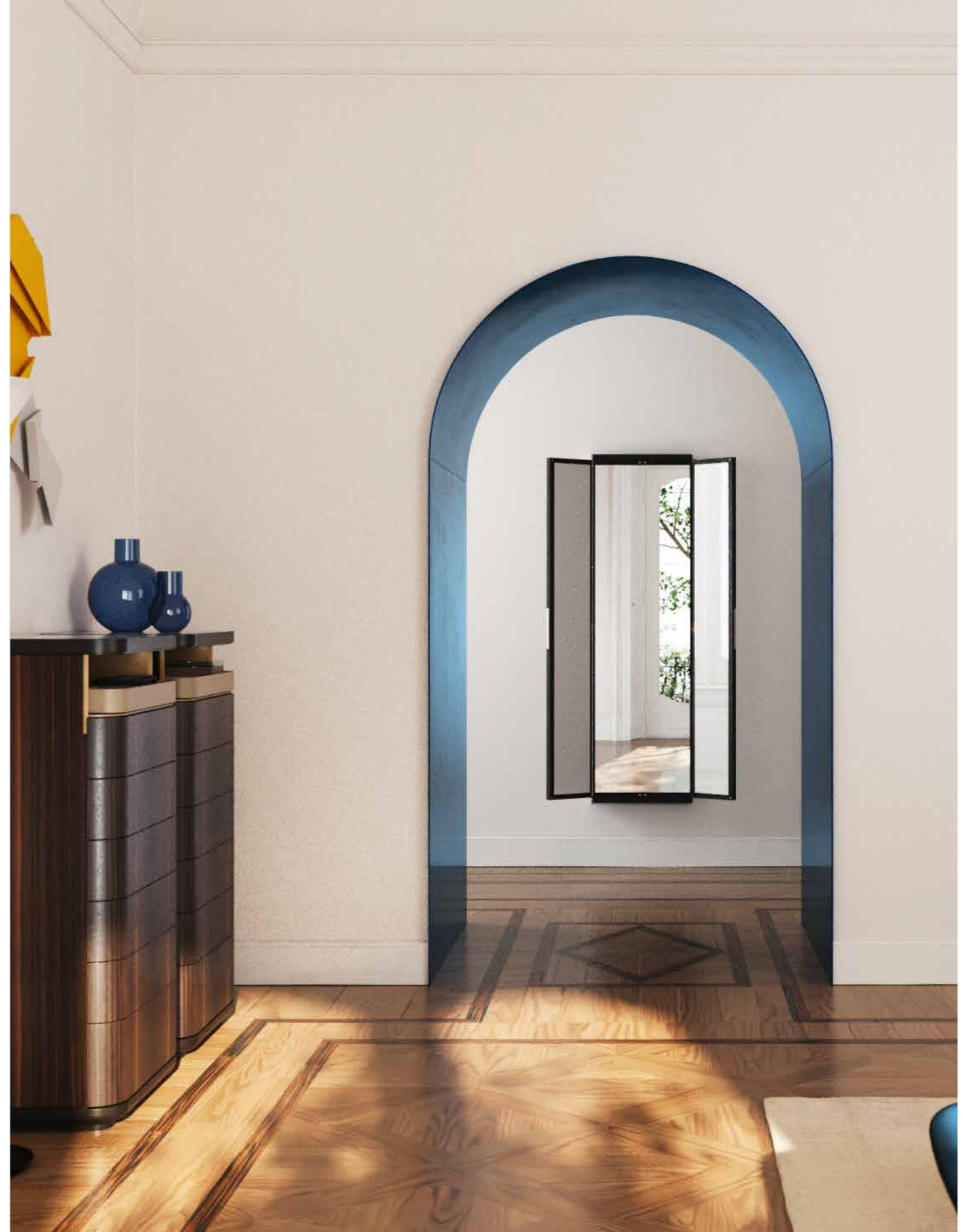



↖ ↑ DUO Vanity, top in colored glass NCS S8010R90B, shelves in Calacatta marble with ash in a Wenge stain structure; DUO Bench, Pelle Frau® SC 278 Atlantic Blue with ash in a Wenge stain structure

Similarly, the armchair DUO Lounge features soft and generous yet light lines thanks to the visible solid ash wood frame that visually winds along the sides to form the legs, providing a contrast of volumes and textures.



↖ ↗ DUO Lounge, armchair upholstered in Pelle Frau® SC
177 Limo with ash in a Wenge stain structure

Roberto Lazzeroni
DUO Lounge



↑ DUO Lounge, armchair upholstered in Pelle Frau® SC 177 Limo with ash in a Wenge stain structure

↗ DUO Lounge, armchair upholstered in Mollis fabric col.1A Milk with ash in a Wenge stain structure





↖ DUO Lounge, armchair upholstered in Mollis fabric col.1A Milk with ash in a Wenge stain structure

↖ ↑ DUO Lounge, armchair upholstered in Ziggy fabric col. Red Onion with ash in a Wenge stain structure

The cozy and sinuous DUO Sofa is available as a single two-seater, a "large" two-seater, or in curved modules to form rounded configurations. All options are designed to encourage sociability and enjoy the pleasure of sharing.

The sofa is upholstered with either removable fabric or an elegant combination of leather and fabric. The sofa's soft lines are a nod to the romanticism of Art Deco, while its flexible plywood structure, the use of recyclable materials, and the production technology encapsulate its contemporary appeal.



↖ ↗ Duo Sofa, 2-seater sofa upholstered in Ziggy fabric col.2627 limon with round black feet

Roberto Lazzeroni
DUO Sofa



↑ ↗ Duo Sofa, 2-seater sofa upholstered in Ziggy fabric col.2627 limon with round black feet





↖ ↑ DUO Sofa, 3-seater sofa upholstered in Botè fabric col.13 Aubergine and back in Pelle Frau® SC 256 Ume with oval shaped feet in burnished and brushed aluminium



↑ DUO Sofa, composition upholstered in Mollis fabric col. 27B Fog with oval shaped feet in burnished and brushed aluminium



↖ ↑ DUO Sofa, composition upholstered in Mollis fabric col. 27B Fog with oval shaped feet in burnished and brushed aluminium

The Duo Bench is a versatile solution, perfect as a decorative element, like most benches it adapts to suit different needs. It can be used as a seat at the table or as a bench at the foot of the bed.

The large version features a wider seat, almost tripled in dimension compared to the previous model. The upholstery is available in leather or woven fabric. The structure, in solid ash wood stained Wenge or Moka, maintains its characteristic slightly curved shape to increase seating comfort.



↑ DUO Bench, upholstered in Pelle Frau® Velvety Paprika with ash in a Wenge stain structure



↑ DUO Bench, (on the left side) upholstered in Pelle Frau® Velvety Gray Salt with ash in a Wenge stain structure

DUO Bench, (in the center) upholstered in Fabric Ziggy Red Onion with ash in a Wenge stain structure

Roberto Lazzeroni
DUO Bench



↑ DUO Bench, upholstered in Pelle Frau® SC 254 Steel Blue with ash in a Moka stain structure



↑ DUO Bench, upholstered in Pelle Frau® Velvety Paprika with ash in a Wenge stain structure

The DUO Chair has a padded seat with sinuous and enveloping lines. Everything about this chair exudes softness juxtaposed with charming playfulness: the inclined rear legs give momentum to the high-back chair or to the armchair which extends obliquely with two endearing 'ears'.

The convex seat plays with the slight concavity of the backrest, shifting the volumes. The plush padding, available fully covered in Pelle Frau® leather, woven fabric, or a combination of Saddle Extra leather with leather or fabric, offers indulgent comfort, inviting relaxed conversation. The legs in solid ash wood are available in a Wenge or Moka stained finish, dyed to sample shade or lacquered to match a RAL colour chart sample.



↑ DUO Small armchair, Fabric Wool Satin Light Marengo with ash in a Wenge stain structure
DUO Chair, Pelle Frau® SC 66 India with ash in a Wenge stain structure



↑ DUO Chair, Pelle Frau® SC 66 India with ash in a Wenge stain structure

Roberto Lazzeroni
DUO Chair/Small armchair



↑ DUO Chair, Pelle Frau® SC 66 India with ash in a Wenge stain structure

↗ DUO Small armchair, Fabric Wool Satin Light Marengo with ash in a Wenge stain structure





↖ Rum qui in nis ilitatecum, apelescipsum cus nihitem nonsequam, sumquam eaquis maionsed que consequi

↑ DUO Chair, Pelle Frau® SC 66 India with ash in a Wenge stain structure

The same architectural silhouette can be found in the DUO Low Tables, made in different heights and with a square, rectangular, or round top. The coffee table top rests lightly on the enveloping wooden frame, which has wide and slender legs, in a modernization of the classic mid-century coffee table.



↑ DUO Low Table, ash in a Wenge stain structure. Low table H 50 with Top in coloured glass NCS S5040Y80R Rosso Cina. Low table H 36 with Top in Calacatta marble



↑ DUO Low Table, ash in a Wenge stain structure. Low table D 80 with Top in coloured glass NCS S8010R90B Blu

DUO Low Table, ash in a Wenge stain structure. Low table D 120 with Top in coloured glass NCS S4005G20Y Celadon

Roberto Lazzeroni DUO Low Table



↑ DUO Low Table, top in coloured glass
NCS S4005G20Y Celadon with ash in
a Wenge stain structure

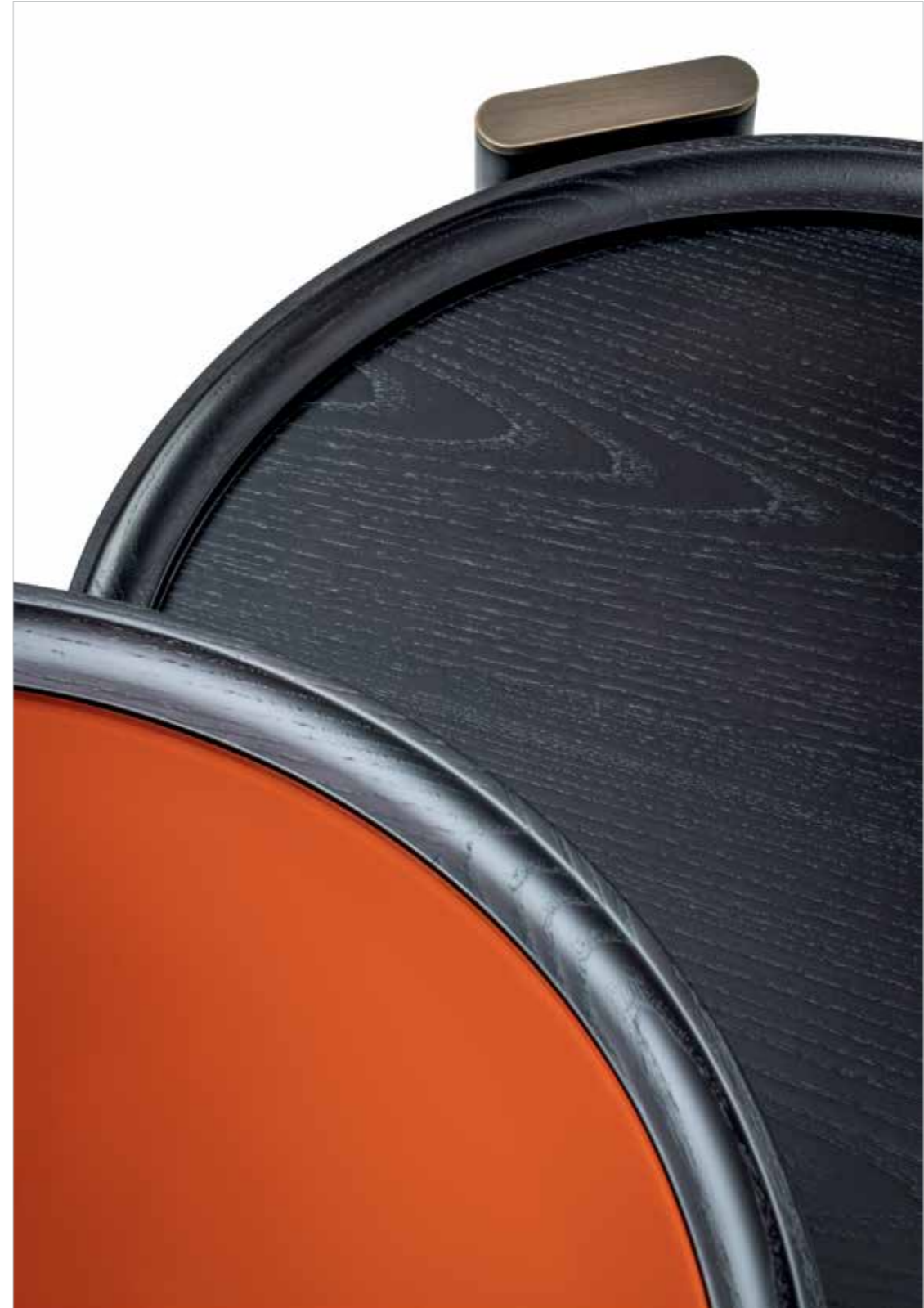

↑ DUO Low Table, ash in a Wenge stain structure.
Low table H 50 with Top in coloured glass
NCS S5040Y80R Rosso Cina

↑ DUO Low Table, ash in a Wenge stain structure.
Low table H 36 with Ash Top in a Wenge stain



↑ ↗ DUO Low Table, top in Total Calacatta marble with ash in a Wenge stain structure



The DUO Pedestal Table, with its round top in two different sizes, features a big sculptural base with a hand-crafted carving motif, making each piece unique and offering an aesthetically striking solution.



↖ DUO Pedestal Table, low table top in Calacatta
Marble with ash in a Wenge stain structure



↑ DUO Pedestal Table, low table top in coloured glass
NCS S3502Y | Grigio with ash in a Moka stain structure

Roberto Lazzeroni
DUO Pedestal Table



↑ DUO Pedestal Table, low table with ash in a Moka stain structure. Low table H 41 with coloured glass top NCS S8010R90B | Blu

DUO Pedestal Table, low table with ash in a Moka stain structure. Low table H 55 with coloured glass top NCS S3502Y | Grigio



↑ DUO Pedestal Table, low table with ash in a Wenge stain structure

The DUO Table is streamlined and elegant with clean lines and soft curves for a minimalist approach. The base, in solid ash wood stained Wenge or Moka, evokes and revamps the style of the DUO coffee tables.

The broad legs are split with an inclined rounded section, connected by a cross frame with bronzed brass elements. This base supports the Calacatta marble top, which can be rectangular (250 or 292 cm) or circular (diameter 150 or 180 cm). Precious materials and functional design make the DUO Table perfect for different spaces and contexts.



↑ DUO Table 292×110, top in Calacatta marble with ash in a Wenge stain structure



↑ DUO Table Ø 180, top in Calacatta marble with ash in a Wenge stain structure

Roberto Lazzeroni
DUO Table



↑ DUO Table 292×110, top in Calacatta marble with ash in a Wenge stain structure

↗ DUO Table 292×110, detail of the solid ash structure

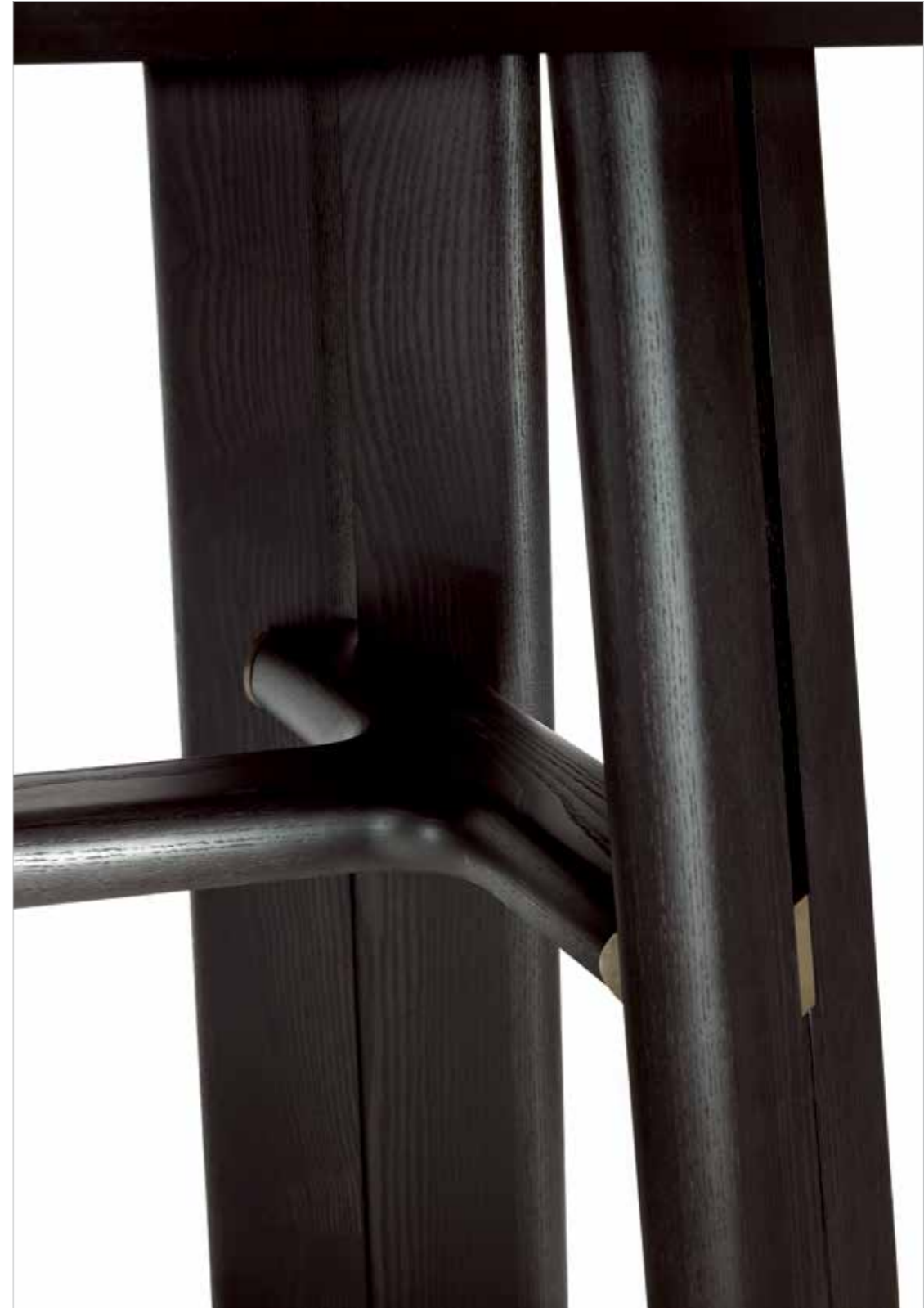

The DUO Trolley features the evocative aesthetics of an old-fashioned romanticism: its double tray (the top one in glass, the bottom one in wood, coloured glass, or marble) and bronzed brass details recall the atmosphere of luxury clubs and cocktail bars of the past.



↖ ↗ DUO Trolley, transparent glass upper top, coloured glass NCS S4005G20Y | Celadon lower top, with ash in a Wenge stain structure

Roberto Lazzeroni
DUO Trolley



↑ DUO Trolley, wheels and metal trim details in brass with a bronze finish

↗ DUO Trolley, smoked glass upper top, Calacatta marble lower top with ash in a Wenge stain structure



The elegant DUO Vanity has a refined and feminine allure, designed for daily personal care rituals. Crafted from solid ash wood in Wenge or Moka finish, it features the typical organic lines that define the entire collection.

Its slender, curved silhouette frames a large round mirror with an adjustable tilt, flanked by two small, mounted shelves available in back-painted glass, or Calacatta marble. Fine metal details, such as the spacers supporting the side shelves and the adjustment mechanism of the mirror, are crafted of solid brass. The central elliptically-shaped shelf is available in back-painted glass, or covered in Pelle Frau® leather, enhancing both elegance and functionality.



↖ DUO Vanity, Top in Pelle Frau® SC 146 Coccio Pesto, shelves in Calacatta marble with ash in a Wenge stain structure



↑ DUO Vanity, top and shelves in colored glass NCS S4005G20Y with ash in a Wenge stain structure

Roberto Lazzeroni DUO Vanity



↑ DUO Vanity, top in Pelle Frau® SC 34 Moggese, shelves in Calacatta marble with ash in a Wenge stain structure



↑ DUO Vanity, top in Pelle Frau® SC 146 Coccio Pesto, shelves in Calacatta marble with ash in a Wenge stain structure

The Duo Bookcase, with either two or four shelves, is a furniture element with an architectural approach, in which the solid ash frame with staggered uprights is softened by the slightly rounded shapes of the shelves (which can be made of wood, coloured glass, or marble).



Roberto Lazzeroni
DUO Bookcase

➤ DUO Bookcase, Top in coloured glass NCS S3005Y50R
Tortora with ash in a Wenge stain structure



↑ DUO Bookcase, top in coloured glass NCS S5040Y80R | Rosso Cina with ash in a Wenge stain structure

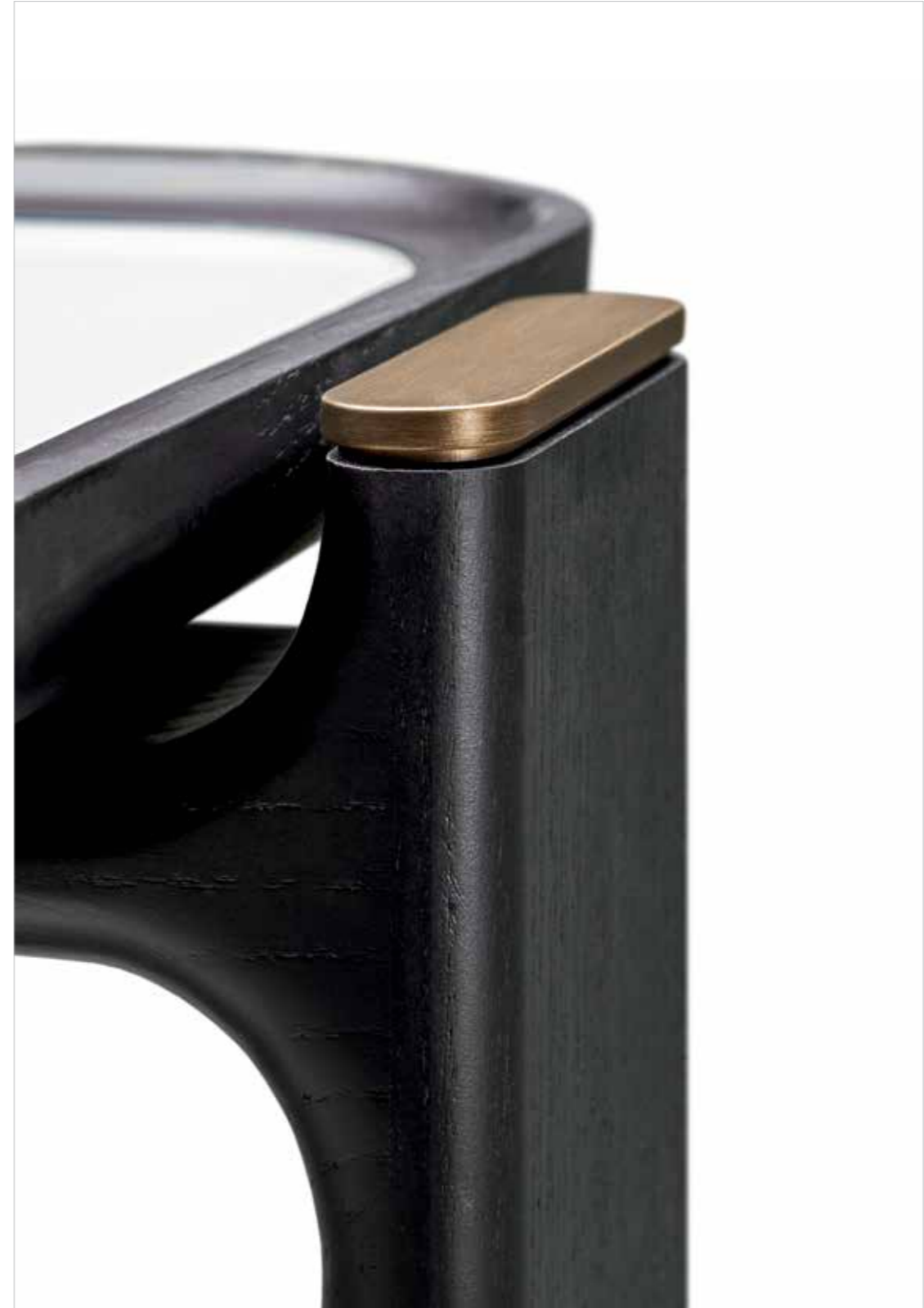

↑ DUO Bookcase, top of the uprights in painted metal shaded bronze

The DUO Cabinet is the storage cabinet available in three versions: high cabinet, low cabinet with two doors and single Bar basket, and two doors and double Bar basket.

The design reinterprets the classic 1950s sideboard: the elegant solid wood structure is lightened by the use of spacers between the base and the cabinet, making the piece visually sleek and contemporary. Available finishes are ebony, natural walnut, inlaid maple or inlaid walnut, which gives it a textured, three-dimensional look. The inside of the cabinet is in maple, which provides a contrast to the outer darker shade.



↑ DUO High Cabinet, 2 doors in ebony with ash in a Wenge stain structure



↗ DUO Low Cabinet, 2 doors and double Bar basket in walnut inlaid with ash in a Wenge stain structure

Roberto Lazzeroni
DUO Cabinet



↑ DUO Cabinet, top of the uprights in painted metal shaded bronze



↑ DUO Low Cabinet, 2 doors and single Bar basket in walnut inlaid with ash in a Wenge stain structure and Calacatta marble top

DUO Internal drawer Low Cabinet, in maple with ash partition in a Wenge stain and drawer bottom in Pelle Frau®SC 173 Glauco



↑ DUO low Cabinet, with internal parts in maple



↗ DUO high Cabinet, with internal parts in maple and accessories in ash in a Wenge stain



↑ DUO high Cabinet, internal drawer in ash in a Wenge stain with partition in maple and drawer bottom in Pelle Frau® SC 173 Glauco



↑ DUO Cabinet, handles in painted metal shaded bronze

Like the DUO Bookcase the DUO Console is a furniture element with an architectural approach, in which the solid ash frame with staggered uprights is softened by the slightly rounded shapes of the shelves (which can be made of wood, coloured glass, or marble).



↖ ↑ DUO Console, Calacatta marble upper top, coloured glass NCS S5040Y80R | Rosso Cina lower top, with ash in a Wenge stain structure

Roberto Lazzeroni DUO Console



↑ DUO Console, Calacatta marble upper top, coloured glass NCS S5040Y80R | Rosso Cina lower top, with ash in a Wenge stain structure



↗ DUO Console, with ash in a Wenge stain structure

DUO Floor Mirror features a special decoration on the frame handcrafted with the gouge carving technique.



↖ ↑ DUO Floor Mirror, ash in a Wenge stain structure

Roberto Lazzeroni
DUO Floor Mirror

The DUO Lamp is the freestanding lighting solution with inverted cone diffuser in white opaline glass and tapered stem in caneté-worked wood, whose design is a nod to the unforgettable geometry of 1950s Italian design icons.

➤ DUO Lamp, ash in a Wenge stain structure



Roberto Lazzeroni
DUO Lamp



↑ ↗ DUO Lamp, cannetè worked ash in a Wenge stain structure with metal trim details painted shaded bronze



Originally an 18th-century side table used in dining rooms, the dumbwaiter is reimagined as an elegant valet stand, perfectly suited for the modern bedroom.

Crafted from solid ash wood, it features a three-legged structure composed of a rear support that splits into a V-shape to form a clothes hanger, and two front supports that create a slightly curved trouser rack. This is embellished with a natural dark brown leather cord, in a shape that evokes the handle of an ancient Japanese katana sword. The valet is available with a lower shelf framed in solid wood and a back-painted glass top, or in the version with a Calacatta marble top.



↖ DUO Valet Stand with ash in a Moka stain structure and leather cord 201 Testa di Moro

↑ DUO Valet stand total marble Calacatta with ash in a Wenge stain structure and leather cord 201 Testa di Moro

Roberto Lazzeroni DUO Valet Stand



↑ DUO Valet Stand, colored glass NCS S3005Y50R with ash in a Wenge stain structure
 DUO Valet Stand Total marble Calacatta with ash in a Wenge stain structure

DUO Valet Stand, colored glass NCS S8010R90B with ash in a Moka stain structure



↑ DUO Valet Stand, colored glass NCS S8010R90B with ash in a Wenge stain structure

The DUO Mirrors are rectangular, round, or square wall mirrors with stained ash wood frame.



↖ ↑ DUO Mirror, ash in a Wenge stain structure

Roberto Lazzeroni
DUO Mirror



↖ ↑ DUO Mirror, ash in a Wenge stain structure



The DUO Rug, in wool and silk, has an elegant geometric pattern available in two shades, Poudre and Dusk Blue, matching perfectly with the hues of the fabrics on the upholstered pieces.



Roberto Lazzeroni
DUO Rug

↖ ↑ DUO Rug, 350x250 rug col. Poudre

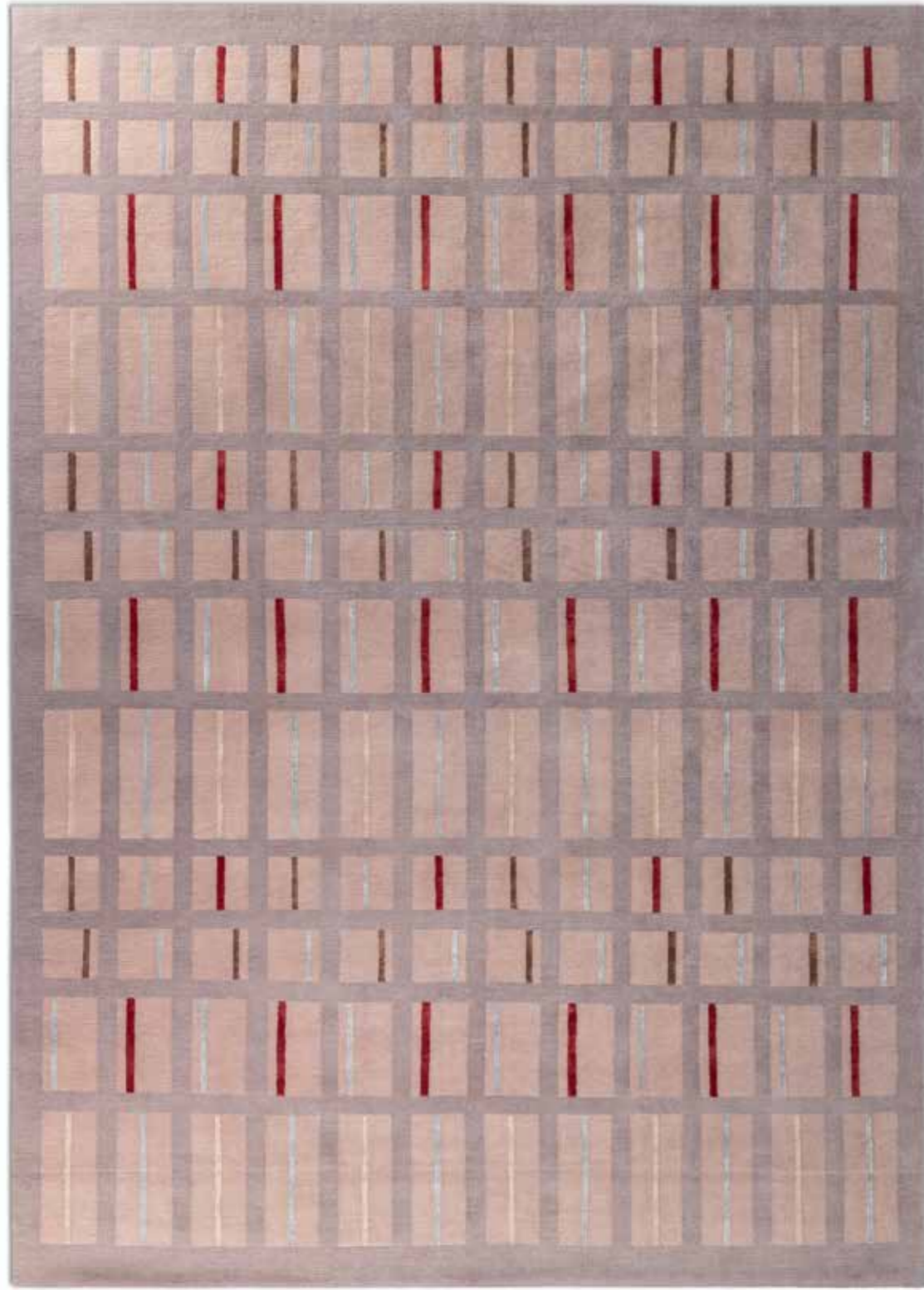

↑ DUO Rug, 350×250 rug col. Poudre

↗ DUO Rug, 350×250 rug col. Dusk Blue

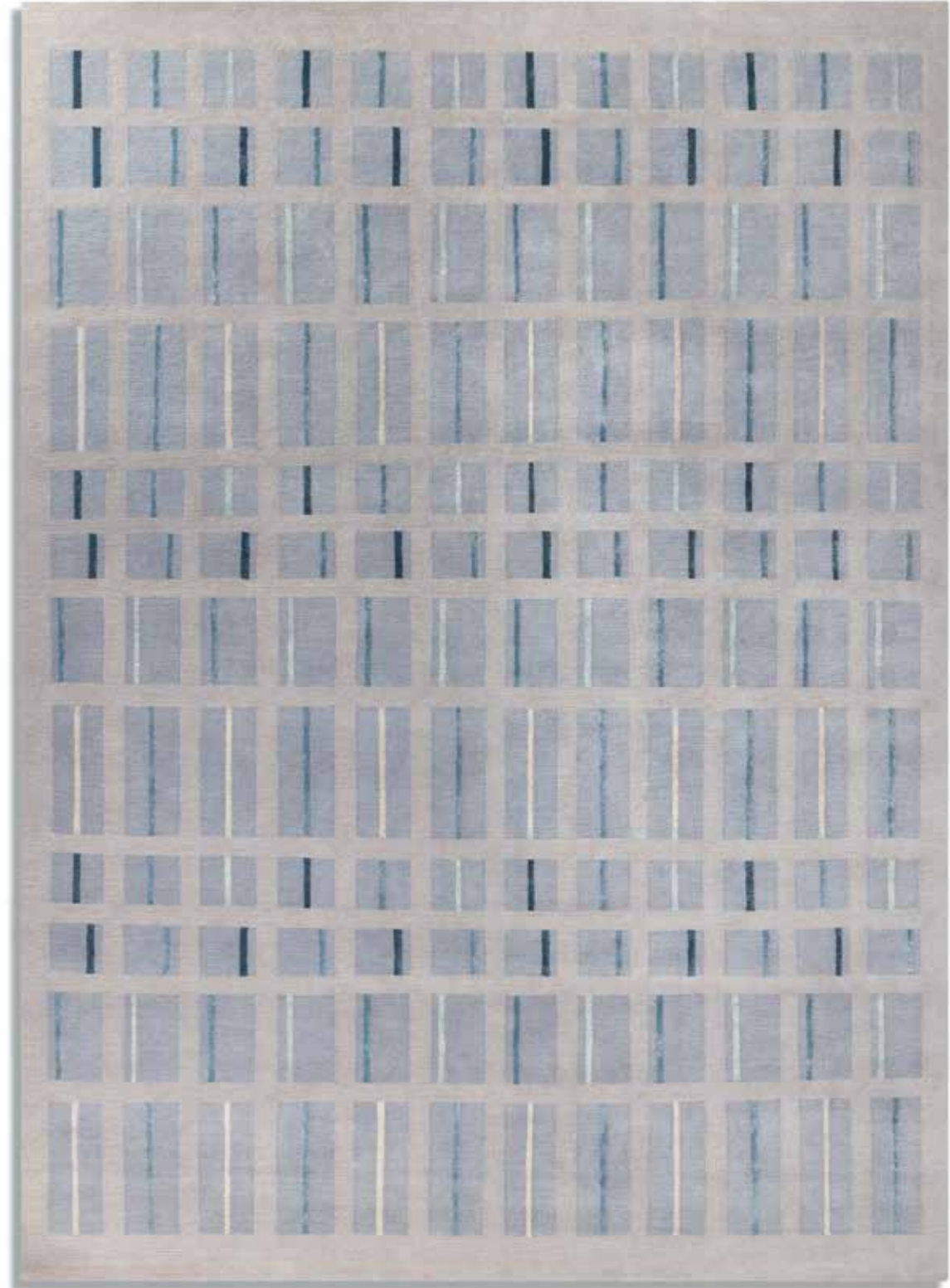

The DUO Screen is the wood-framed divider that can easily adapt to the most diverse domestic contexts thanks to the possibility of fully customizing the panels with wallpaper or fabric.



➤ DUO Screen, room divider composition of 4 modules with ash in a Wenge stain structure and covering in wallpaper Puro 27000A Mushroom

Roberto Lazzeroni
DUO Screen



A poetic, yet extremely functional object, the tri-fold mirror evokes the sophistication of a haute couture atelier.

Crafted with mirrors inserted into a solid ash frame, once opened it can provide various angles of reflection as needed. When not in use, the two side-folding doors can be pushed together to mimic the shape of a closed door, thanks to the discreet external covering in fluted ash. The mirror can also be wall-mounted using of a bayonet anchoring mechanism.



↔ ↗ DUO Triptych Mirror, ash in a Wenge stain structure



Roberto Lazzeroni
DUO Triptych Mirror

The standout piece of the nighttime collection is the contemporary Duo Bed, characterized by its soft and inviting shapes.

Elegantly elevated above the floor on four L-shaped legs in solid ash - echoing the design of the Duo cabinet and coffee table- it reinterprets some of the collection's distinctive elements. The tapered oval bedframe seamlessly slots into the extended headboard, which projects beyond the structure to envelop the frame. The distinctive matelassé stitching, inspired by the high-end mastery of luxury leather goods, adds a refined touch of sophistication. A decorative bevelled edge elegantly outlines the profile of the bed, while its delicately tapered lateral legs lend a sense of lightness and dynamism. The result is an elegant bed with a distinctly horizontal presence, that takes centre stage while remaining in perfect harmony with the rest of the collection.



Roberto Lazzeroni DUO Bed

↖ ↑ DUO Bed, Pelle Frau® SC 40 Cachemire with quilt
in SC 22 Chiffon and ash in a Wenge stain feet



↑ Detail of the solid ash wood foot with a Wenge finish and the metallic element that defines and enhances it

↗ Detail of the leather quilting on the bed's headboard and the decoration on the mantel achieved with tone-on-tone stitching

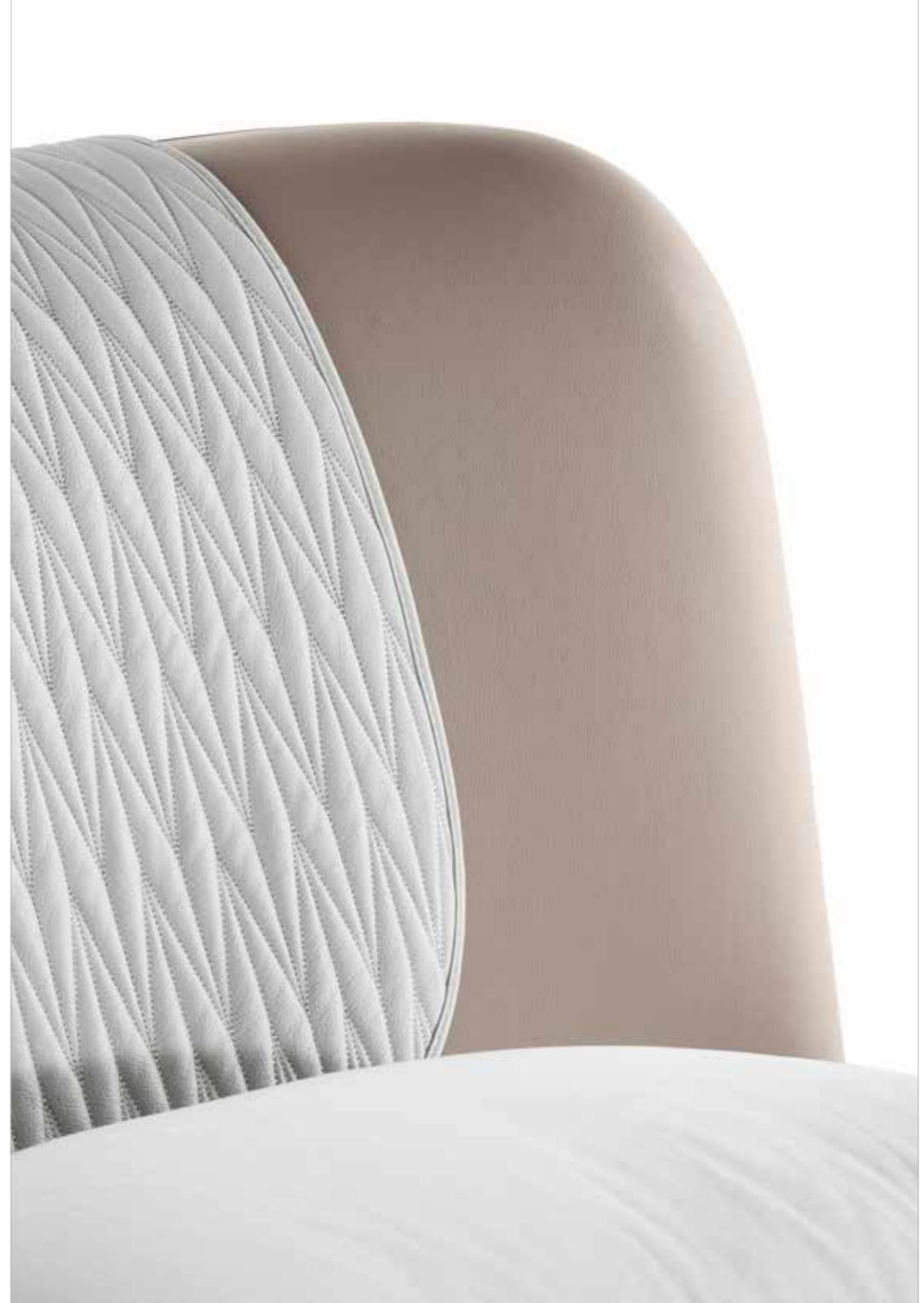

The DUO Bedside Tables feature a pared-back aesthetic, skilfully balanced by the richness of the materials. The structure and the frame of the shelf are in solid ash wood, available in Wenge or Moka stained finishes.



↖ DUO Bedside Table with drawer, top in calacatta with ash in a Wenge stain structure

The standard version has two slanting side supports connected by a crosspiece, supporting a single tabletop. For increased comfort and functionality, a second shelf can be added. The premier version has a drawer carved in solid wood with bevelled corners and an integrated handle on the lower front rim, ensuring smooth opening and closing. The table top is available in different finishes (ash, Calacatta marble, back-painted glass or ColorSphere® leather) to maximise bespoke customisation, just as the various configurations with the drawer, shelf or crosspiece offer functionality that can be adapted to individual needs.



↑ DUO Bedside Table, top in Pelle Frau® SC 133 Paglierino with ash in a Wenge stain structure

↑ DUO Bedside Table with shelf, top in colored glass NCS S8010R90B with ash in a Moka stain structure
DUO Bedside table with drawer, top in calacatta with ash in a Wenge stain structure

Roberto Lazzeroni DUO Bedside Table

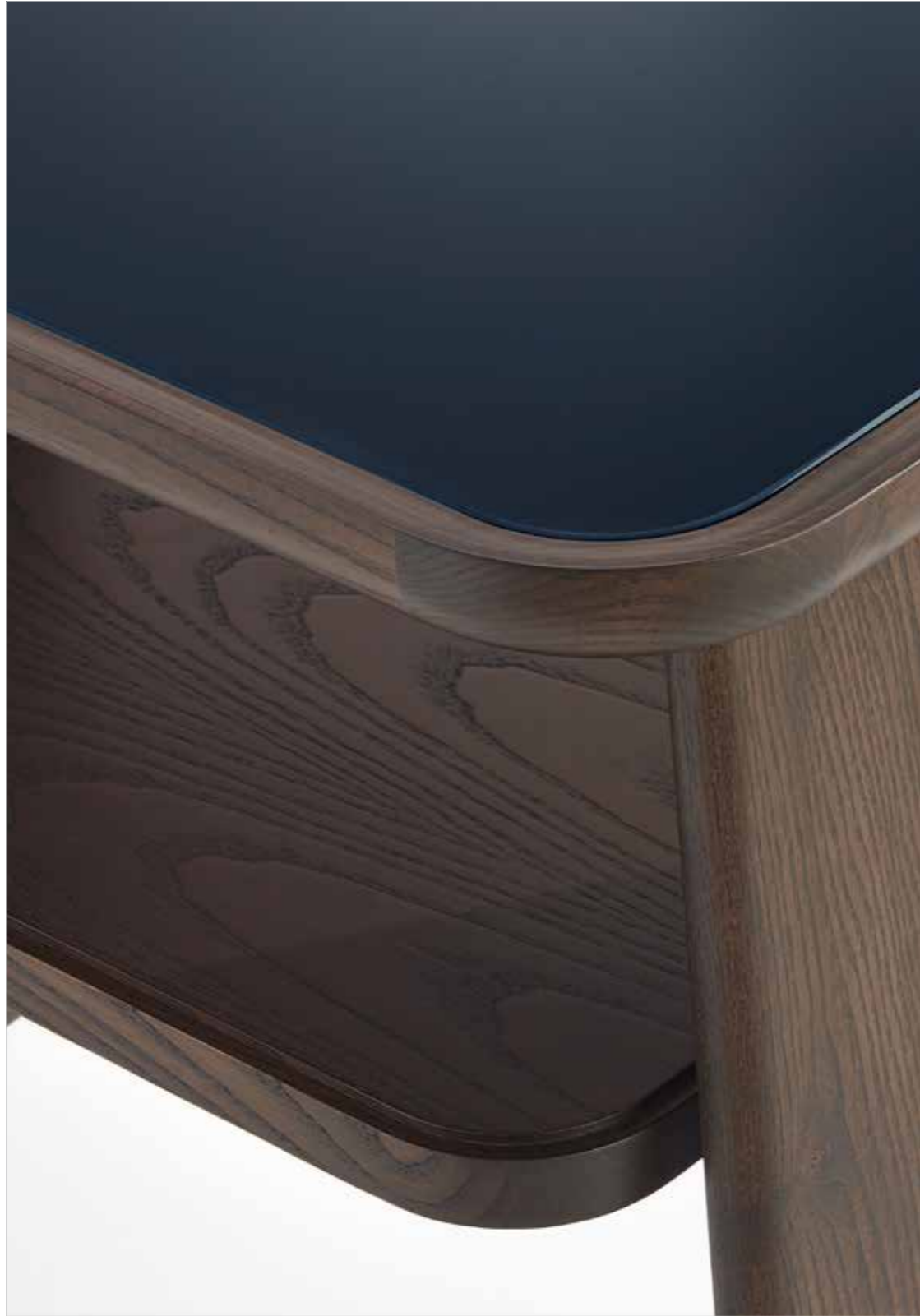

↑ DUO Bedside Table with shelf, top in colored glass
NCS S8010R90B with ash in a Moka stain structure



↑ DUO Bedside Table, top in Pelle Frau® SC 133
Paglierino with ash in a Wenge stain structure

The DUO Chest of Drawers is inspired by the classic settimino or 'seven-drawer chest' intended for weekly clothes storage. This reinterpretation transforms the original concept into an elegant, upright night chest.

Six spacious drawers are topped with a small open compartment, softly illuminated by a touch-control LED light. A removable tray with four smaller compartments, covered in Pelle Frau®, can be inserted into this space for added organization. The base and frame are made of (solid) ash wood, and the chest of drawers is available with an exterior wrap-around finish in ebony or walnut, inlaid walnut, maple or inlaid maple. The latter finish enriches the overall aesthetic thanks to a sophisticated play of textures, alternating the natural wood grain with a gradated tile motif. The final exquisite detail is the seamlessly set-in top in Calacatta marble or lacquered glass (or in ash to match the structure).



➤ DUO Chest of Drawers, top in Calacatta, external parts in ebony, sliding tray in Pelle Frau® SC 34 Muggese with ash in a Wenge stain structure

Roberto Lazzeroni
DUO Chest of Drawers



↖ ↑ DUO Chest of Drawers, top in Calacatta, external parts in ebony, sliding tray in Pelle Frau® SC 34 Maggese with ash in a Wenge stain structure



Translations

- 158 Italian translation
- 159 French translation
- 159 Chinese translation

Technical Drawings

- | | | | |
|-----|----------------------|-----|---------------------|
| 162 | DUO Bed | 170 | DUO Low Table |
| 162 | DUO Bedside Table | 172 | DUO Mirror |
| 163 | DUO Bench | 173 | DUO Pedestal Table |
| 164 | DUO Bookcase | 174 | DUO Rug |
| 165 | DUO Cabinet | 174 | DUO Screen |
| 166 | DUO Chair | 175 | DUO Sofa |
| 167 | DUO Chest of Drawers | 177 | DUO Table |
| 168 | DUO Console | 178 | DUO Triptych Mirror |
| 168 | DUO Floor Mirror | 178 | DUO Trolley |
| 168 | DUO Lamp | 178 | DUO Valet Stand |
| 169 | DUO Lounge | 179 | DUO Vanity |

Translations and Technical Drawings DUO Collection

IT
La collezione disegnata da Roberto Lazzeroni rappresenta il primo capitolo della collaborazione tra i due brand, la cui sinergia progettuale è espressa attraverso una gamma di prodotti che racchiudono il passato e il presente delle due aziende eccellenze del Made in Italy.

La **DUO Collection** prende il nome dal concetto di unione di due elementi che non corrisponde alla semplice somma dei singoli, ma rappresenta «due esperienze che generano un pensiero comune». In DUO, la singolarità non perde la propria identità, ma viene esaltata nell'atto creativo condiviso. La collezione si sviluppa a partire da due concetti apparentemente opposti, la **Memoria** e l'**Innovazione**. I due percorsi, quello che porta alla valorizzazione del passato e quello che si proietta verso nuovi orizzonti contemporanei, trovano il loro punto d'incontro in una linea di oggetti senza tempo, trasversali e dall'eleganza essenziale.

L'atmosfera che ha ispirato lo sviluppo della DUO Collection è quella della Dolce Vita italiana, evocativa di uno stile di vita spensierato, naturalmente elegante e incline al godersi il piacere della socialità. I prodotti sono pensati per dare forma a un ambiente living romantico e accogliente, ispirato ai “sallotti” degli anni '50 di un'Italia in rinascita e in pieno fermento intellettuale e creativo post-bellico. Silhouette dal sapore retrò che colgono lo spirito del tempo, eppure perfettamente adattabili anche ai contesti domestici contemporanei grazie alla versatilità delle forme morbide, delle accurate proporzioni e delle preziose scelte materiche per le finiture.

Il **DUO Sofa**, accogliente e sinuoso, è disponibile in versione singola a due posti, due posti “large” o a moduli componibili curvilinei a formare delle configurazioni arrotondate che invitano alla socialità e al piacere della condivisione. Preziosi rivestimenti in tessuto sfoderabile oppure ricercati abbinamenti della pelle al tessuto costituiscono la preziosa seconda pelle della seduta. Le linee morbide del divano strizzano l'occhio al romanticismo dell'Art Déco, mentre la sua struttura flessibile in multistrato, l'uso di materiali riciclabili e la tecnologia di produzione ne racchiudono tutta la contemporaneità.

Allo stesso modo, la **DUO Lounge** è la poltrona caratterizzata da linee soffici e generose eppure leggere, grazie alla solida struttura in legno massello di frassino tinto Moka o Wenge a vista che si snoda visivamente lungo i fianchi a comporre le gambe, in un contrasto di volumi e matericità che la rende ideale per sia per accompagnare il divano sia per vivere in autonomia.

La Panca **DUO Bench** è una soluzione versatile, perfetta come elemento decorativo, seduta da mettere a fianco del tavolo o come panca fondo letto. Presenta un **sedile più ampio**, quasi triplicato rispetto al modello precedente. Il rivestimento può essere in Pelle Frau® o in tessuto. La struttura, in legno massello di frassino tinto Wenge o Moka, mantiene la caratteristica forma leggermente curva per aumentare il comfort di seduta.

La **DUO Chair** è una seduta imbottita dalle linee sinuose e avvolgenti. Tutto, in questa poltroncina, comunica un **senso di morbidezza e al tempo stesso di dinamismo**: le gambe posteriori inclinate conferiscono slancio **alla sedia dallo schienale alto o alla poltroncina** che si allarga lateralmente in due “orecchie” accoglienti. Il sedile convesso gioca con la leggera concavità dello schienale, movimentando i volumi. La ricca imbottitura, completamente rivestita in Pelle Frau® o tessuto, aggiunge un surplus di comfort e invita al relax e alla conversazione. Le gambe in legno massello di frassino possono essere in finitura tinto Wenge o Moka, tinto a campione o laccato RAL a campione.

Il **DUO Rug**, in lana e seta, presenta un elegante pattern geometrico disponibile in due tonalità, Poudre e Dusk Blue, che si sposano perfettamente con le tonalità dei tessuti di rivestimento degli imbottiti.

Il **DUO Cabinet** è il mobile contenitore declinato in tre versioni: high cabinet, low cabinet a due ante e cestello Bar e a due ante e due cestelli Bar. Il design rivisita la classica credenza anni Cinquanta: l'elegante struttura in legno massello è alleggerita grazie all'utilizzo di distanziali tra la base e il contenitore, che rendono il mobile visivamente slanciato e contemporaneo. La finitura del contenitore è disponibile in ebano, noce naturale oppure in noce intarsiato, che gli conferisce un aspetto texturizzato e tridimensionale. L'interno del contenitore è in acero, che contrasta con la tonalità più scura dell'esterno in un dualismo di materiali dal forte impatto visivo.

La **DUO Bookcase**, disponibile a due e a quattro ripiani, e la **DUO Console** sono elementi d'arredo dall'approccio architettrurale, in cui la struttura in massello di frassino con montanti sfalsati è addolcita dalle forme leggermente stondate dei ripiani, che possono essere in legno, vetro verniciato oppure marmo.

La stessa silhouette architettrurale la si ritrova nei **DUO Low Table**, realizzati in diverse altezze e con piano quadrato, rettangolare oppure rotondo. Il top del tavolino poggia con leg-

gerezza sulla struttura avvolgente in legno, che ha gambe larghe e sottili, in un'attualizzazione del classico coffee table Mid-Century.

DUO Table, realizzato da Ceccotti Collezioni in **quattro varianti**, ha un design essenziale ed elegante, con linee pulite e curve morbide per un approccio minimalista alle forme. Il solido basamento, in legno massello di frassino tinto Wenge o Moka, recupera lo stile e il disegno dei tavolini DUO rielaborandolo. Le gambe sono infatti composte da grandi tavole a sezione rotonda inclinata, collegate tra loro da una crociata con elementi in ottone bronzato. Il basamento sorregge il top in Marmo Calacatta, che può essere di forma rettangolare (250 o 292 × 110 cm) o circolare (diametro di 150 o 180 cm). *DUO Table* è il primo esempio a catalogo per Ceccotti Collezioni di un tavolo con piano in marmo mono-lastra libero, senza cornice in legno. Preziosità materiche e design funzionale rendono *DUO Table* perfetto per spazi e contesti diversi.

L'estetica evocativa di un romanticismo d'altri tempi la si ritrova nel **DUO Trolley**, che col suo doppio ripiano (superiore in vetro, inferiore in legno, vetro verniciato oppure marmo) e i dettagli in ottone bronzato richiama le atmosfere dei lussuosi club e cocktail bar del passato.

Il tavolino **DUO Pedestal Table**, disponibile a catalogo con top tondo in due diverse misure, presenta un importante basamento scultoreo con motivo a intaglio realizzato a mano, che rende ciascun pezzo unico e offre una soluzione di grande impatto estetico. La **DUO Bench** è una piccola panca in massello di frassino dalla forma leggermente curva, con la seduta rivestita in tessuto o in pelle.

La piantana **DUO Lamp**, con il diffusore a forma di cono rovesciato in vetro opalino bianco e lo stelo affusolato in legno con lavorazione a canneté, strizza l'occhio alle geometrie indimenticabili del lighting design italiano degli anni Cinquanta.

Completa la zona living il complemento **DUO Screen**, il paravento con cornice in legno che può adattarsi facilmente ai contesti domestici più variegati grazie alla possibilità di personalizzare completamente i pannelli con la carta da parati o il tessuto che si preferisce. I **DUO Mirror** sono gli specchi da parete, rettangolari, rotondi o quadrati, con cornice in legno di frassino tinto Wenge' e tinto Moka e il **DUO Floor Mirror**, che presenta una speciale decorazione sulla cornice realizzata a mano con la tecnica dell'intaglio a sgorbia.

Protagonista della collezione è **DUO Bed**, un letto dal design contemporaneo, caratterizzato da forme morbide e accoglienti. Sospeso da terra su quattro gambe in massello di frassino a forma di “L” rovesciata - un richiamo al mobile e al tavolino DUO - reinterpretata con eleganza alcuni elementi distintivi della collezione.

Il giroletto, dalla sezione ellittica e dal profilo affusolato, si incastra nella testiera aggettante, che si estende oltre la struttura per creare un effetto avvolgente. Il motivo matelassé, ispirato alle lavorazioni di alta gamma della pelletteria di lusso, aggiunge un tocco di sofisticata eleganza. Un bordo smussato decorativo delinea il profilo del letto, mentre le gambe laterali, sottili e leggere, ne enfatizzano la dinamicità. Il risultato è un letto dal carattere deciso, con una presenza orizzontale marcata, perfettamente in equilibrio con il resto della collezione.

I comodini **DUO Bedside Table** hanno una particolare linea aperta ed essenziale, bilanciata dalla ricchezza materica. La struttura e la cornice del ripiano sono infatti in legno massello di frassino, disponibile nelle finiture tinto Wengé o Moka. La versione base presenta due montanti inclinati, connessi da un traverso, che sostengono un unico piano di appoggio. Per maggior comfort e funzionalità, è possibile aggiungere un secondo piano d'appoggio La variante più ricca presenta invece un cassetto scolpito in legno massello dagli angoli sagomati con una maniglia integrata sul bordo inferiore del lato frontale, per facilitare l'apertura e la chiusura. Il top è disponibile in diverse finiture (frassino, marmo Calacatta, vetro retro-verniciato o Pelle Frau ColorSphere®) che consentono un'estrema personalizzazione, così come le varie configurazioni con cassetto, ripiano o traversa offrono funzionalità adattabili alle esigenze individuali.

La cassettera **DUO Chest of Drawers** nasce dal classico “settimino” dedicato al cambio d'abito quotidiano, e lo reinterpreta trasformandosi in un elegante contenitore dalla linea slanciata. Presenta sei cassetti spaziosi e un piccolo vano a giorno, impreziosito da una luce LED con accensione touch control che illumina delicatamente l'interno. Nel vano a giorno può essere inserito un cassetto scorrevole, rivestito in Pelle Frau® e diviso in quattro scomparti. Basamento e cornice Realizzata in legno (massello) di frassino, la cassettera può avere una finitura esterna su tutti i lati in ebano oppure noce, noce intarsiato, acero o intarsiato. Quest'ultima finitura arricchisce l'estetica complessiva grazie a un sofisticato gioco di texture che alterna il disegno naturale del legno con tagli verticali di grande impatto visivo. Det-

taglio finale di grande raffinatezza è il piano in marmo Calacatta o in vetro laccato (oppure in frassino in abbinamento alla struttura), incorniciato senza soluzione di continuità.

Oggetto poetico e al tempo stesso estremamente funzionale, lo Specchio a tre ante **DUO Triptych Mirror** evoca l'atmosfera sofisticata di un atelier di alta sartoria. Realizzato con specchi inseriti in una cornice in frassino massiccio permette, una volta aperto, di specchiarsi comodamente da varie angolazioni. Quando non è in uso, le due ante laterali possono essere accostate, creando l'effetto di una porta chiusa grazie al raffinato rivestimento esterno in frassino cannetato. Può essere fissato al muro grazie a un meccanismo di ancoraggio a baionetta.

Il servomuto, nato nel XVIII secolo come complemento di supporto per i commensali, diventa un raffinato in dossatore, perfetto per la camera da letto moderna. **DUO Valet Stand**, realizzato in legno massello di frassino, ha una struttura a tre gambe composta da un montante posteriore che si divide a V e sostiene un appendiabiti, e da due montanti anteriori che sostengono un porta-pantaloni leggermente curvo, impreziosito da un cordino in pelle naturale colore testa di moro, dalla linea simile alla forma (che ricorda l'impugnatura) di un'antica katana giapponese. È disponibile con un ripiano inferiore incorniciato in legno massiccio e un piano in vetro retro verniciato, oppure nella versione con piano in marmo Calacatta.

La Toeletta **DUO Vanity** è un mobile elegante e raffinato, molto femminile, al carattere delicatamente femminile, pensato per i rituali quotidiani della cura di sé. Realizzata in legno massello di frassino in finitura Wengé o Moka, presenta le tipiche linee organiche comuni a tutta la collezione. La sua delicata silhouette curva incornicia un ampio specchio tondo inclinabile, affiancato da due piccoli ripiani incastonati a filo e realizzati in vetro retro-verniciato, o marmo Calacatta. I raffinati dettagli metallici, come i distanziali dei pianetti laterali e il meccanismo di regolazione dello specchio, sono realizzati in ottone massiccio. Il ripiano centrale ha una forma ellittica e può essere in vetro retro-verniciato, oppure rivestito in pelle Pelle Frau®.

La collection imaginée par Roberto Lazzeroni constitue le premier chapitre de la collaboration entre les deux marques. Leur synergie conceptuelle se traduit par une gamme de produits qui recèlent en eux le passé et le présent des deux entreprises d'excellence du Made in Italy.

La **DUO Collection** tire son nom du concept d'union de deux éléments ne correspondant pas à la simple somme des deux mais représente « deux expériences qui engendrent une pensée commune ». Dans DUO, l'individualité ne perd pas son identité mais est sublimée dans l'acte de création partagée. La collection se développe à partir de deux concepts qui, en apparence, s'opposent : la « mémoire » et l'« innovation » Les deux parcours, celui qui mène à la valorisation du passé et celui qui se projette vers de nouveaux horizons contemporains, trouvent un point de rencontre dans une gamme d'objets intemporels, transversaux et à l'élégance minimaliste. L'ambiance qui a inspiré le développement de la **DUO Collection** est celle de la « dolce vita » italienne, évocatrice d'un style de vie empreint de désinvolture, à l'élégance intrinsèque et enclin à profiter au maximum du plaisir d’être ensemble. Les produits sont étudiés pour donner vie à un environnement living romantique et accueillant, inspiré des « salons » des années cinquante d'une Italie en pleine renaissance et en pleine effervescence intellectuelle et créative d'après-guerre. Des formes au style rétro qui capturent l'esprit du temps et qui, pourtant, sont aussi parfaitement adaptables aux habitations contemporaines grâce à la polyvalence des lignes douces, des proportions soignées dans le moindre détail et des matières nobles choisies pour les finitions.

Le canapé **DUO Sofa**, accueillant et courbe, est décliné en version simple à deux places, en deux places plus larges et en modules aménageables curvilignes pour créer des compositions arrondies invitant à la sociabilité et au plaisir de partager. De superbes revêtements en tissu déhoussable ou bien des associations recherchées entre cuir et tissu deviennnt la précieuse seconde peau de l'assise. Les lignes douces du canapé sont un clin d’œil au romantisme de l'Art déco, tandis que la structure flexible en multiplis, l'utilisation de matériaux recyclables et la technologie de production portent en eux toute sa contemporanéité.

De la même manière, le fauteuil **DUO Lounge** est caractérisé par des lignes douces et généreuses. Mais il est également placé sous le signe de la légèreté grâce à sa structure solide et visible en frêne massif teinté Moka ou Wenge qui s'articule le long des côtés pour former les pieds, dans un contraste

de volumes et de matières qui en font l'idéal aussi bien pour accompagner le canapé que pour être utilisé seul.

La banquette **DUO Bench** est une solution polyvalente, parfaite comme élément décoratif, comme siège à placer à côté de la table ou comme banquette au bout du lit. Il se caractérise par un **asse plus large**, presque trois fois plus large que le modèle précédent. Le revêtement peut être en cuir Pelle Frau® ou en tissu. La structure, en frêne massif teinté Wenge o Moka, conserve la forme caractéristique légèrement incurvée pour augmenter le confort d'assise.

La **Chaise DUO** est un siège rembourré aux lignes sinueuses et chaleureuses. Tout dans ce fauteuil communique un **sensation de douceur et en même temps de dynamisme** : les pieds arrière inclinés donnent de l'élan **à la chaise à haut dossier ou au petit fauteuil** qui s'élargit latéralement en deux chaleureuses « oreilles ». L'assise convexe joue avec la légère concavité du dossier, en déplaçant les volumes. Le riche rembourrage, entièrement recouvert de tissu ou de cuir Pelle Frau®, ajoute un confort supplémentaire et invite à la détente et à la conversation. Les pieds en frêne massif peuvent être teintés Wenge ou Moka, teintés ou laqués RAL de la couleur de l'échantillon fourni par le client.

Le tapis **DUO Rug**, en laine et soie, présente un élégant motif géométrique décliné dans deux tonalités, Poudre et Dusk Blue, qui se marient à la perfection avec les teintes des tissus des revêtements des éléments rembourrés. Le **DUO Cabinet** est un meuble de rangement décliné dans trois versions : high cabinet, low cabinet à deux portes, panier-bar et à deux portes et deux paniers-bar. Le design réinterprète le buffet classique des années cinquante : la structure élégante en bois massif est allégée grâce à des entretoises entre la base et le rangement, rendant le meuble visuellement plus élané et contemporain. La finition du rangement existe en ébène, noyer naturel ou bien noyer incrusté qui confère au meuble un aspect texturisé et tridimensionnel. L'intérieur du meuble de rangement est en érable, en contraste avec la tonalité plus foncée de l'extérieur, et joue sur une dualité de matières très impactante sur le plan visuel.

La bibliothèque **DUO Bookcase**, qui existe en version à deux ou à quatre étagères, et la console **DUO Console** sont des éléments de mobilier à l'approche architecturale, où la structure en hêtre massif aux montants asymétriques est adoucie par les formes légèrement arrondies des étagères. Ces dernières peuvent être en bois, en verre peint ou encore en marbre.

Ces mêmes lignes architecturales se retrouvent dans les tables basses **DUO Low Table** déclinées en différentes hauteurs et avec un plateau carré, rectangulaire ou rond. Le plateau de la table basse s'appuie avec légèreté sur la structure enveloppante en bois qui présente des pieds larges et fins, pour une réinterprétation actuelle de la table basse Mid-Century classique.

DUO Table, produite par Ceccotti Collezioni **en quatre variantes**, a un design essentiel et élégant, avec des lignes épurées et des courbes harmonieuses pour une approche minimaliste des formes. Le piètement robuste, en frêne massif teinté Wenge ou Moka, reprend le style et le design des tables DUO, en le retravaillant. Les pieds sont en effet composés de grandes planches à section ronde inclinée, reliées par une croix avec des éléments en laiton bronzé. Le piètement supporte le plateau en marbre Calacatta, qui peut être rectangulaire (250 ou 292 cm) ou circulaire (diamètre de 150 ou 180 cm). *DUO Table* est le premier exemple dans le catalogue de Ceccotti Collezioni d'une table avec un plateau réalisé en une seule plaque de marbre, sans cadre en bois. La préciosité des matériaux et le design fonctionnel rendent *DUO Table* idéale pour différents espaces et contextes.

L'esthétique suggestive d'un romantisme révolu se retrouve dans le chariot **DUO Trolley** qui, avec sa double étagère (supérieure en verre, inférieure en bois, verre peint ou marbre) et ses détails en laiton effet bronze, rappelle les ambiances typiques des prestigieux clubs privés et des bars à cocktail d'antan.

La table basse **DUO Pedestal Table** qui existe avec plateau rond de deux tailles différentes, présente un piètement architectural imposant reprenant un motif sculpté à la main à la gouge, rendant chaque pièce unique, et offrant une solution du plus bel effet esthétique. Le **DUO Bench** est un petit banc en hêtre massif à la forme légèrement courbée, dont l'assise est revêue de tissu ou de cuir. La lampe de sol **DUO Lamp**, avec son diffuseur en forme de cône renversé en opaline blanche et son pied fuselé en bois cannelé, est un clin d’œil aux géométries mémorables du lighting design italien des années cinquante. Pour parachever le mobilier du living, voici le paravent **DUO Screen**, dont le cadre en bois s'adapte aisément aux contextes domestiques les plus divers grâce à la possibilité de personnaliser entièrement les quatre panneaux avec du papier peint ou le tissu de son choix. **DUO Mirror** s'agit de miroirs muraux, rectangulaires, ronds ou carrés, dont le cadre est en hêtre teinté et le **DUO Floor Mirror**, un miroir qui présente une décoration spéciale sur le cadre réalisée à la main avec la technique de sculpture à la gouge.

DUO 床头柜采用开放且极简的设计，辅以丰富的材质质感形成平衡。结构和台面边框均由实心白蜡木打造，提供Wengé（乌木色）或 Moka（摩卡色）两种饰面选择。基础版本采用两根倾斜支撑腿，通过一条横梁连接，支撑单层置物台面。为了增强实用性和舒适性，可额外增加一层置物板。升级版本配备雕刻感十足实木抽屉，圆润的倒角设计，前面板底部内嵌把手，方便开合。台面可选择白蜡木、卡拉卡塔大理石、背漆玻璃或 Pelle Frau ColorSphere® 真皮等多种材质，充分满足个性化搭配需求。多种组合形式（抽屉、置物板或横梁）灵活适应不同的功能需求。

DUO 五斗柜灵感源自经典的“七斗柜”（用于日常更换衣物），以优雅修长的比例重新演绎，成为一件别致的收纳家具。配备六个大容量抽屉和一个开放格，内置触控开启的 LED 灯，柔和照亮内部空间。开放格内可加入一只 Pelle Frau® 真皮包覆的滑动抽屉，内部分为四个隔层，方便分类收纳。

底座与框架均由实心白蜡木制成，外部可选择全方位乌木、胡桃木、镶嵌胡桃木、枫木或拼花饰面。拼花版本通过自然木纹与竖切纹理的对比，营造出极具视觉冲击力的精美质感。顶部可选卡拉卡塔大理石或漆面玻璃（亦可选择与结构同色白蜡木），无缝嵌入框架，尽显优雅精致。

这款极具诗意又实用的三折镜，唤起高级定制裁缝工坊的精致氛围。镜面镶嵌于实心白蜡木框架中，展开后可从多个角度自由照映自己。不使用时，左右两扇侧翼可合拢，形成一扇“关闭”的门面效果，外层饰以精美的白蜡木直纹饰面。可通过卡口式挂墙系统固定在墙面上，稳固安全。

这款源于18世纪的“绅士架”——最初为宴会宾客设计的辅助家具——在现代卧室中化身为优雅的衣物挂架。采用实心白蜡木打造，三腿结构设计：后方一支竖柱分叉成“V”型，支撑衣架；前方两支斜柱支撑轻微弯曲的裤架。裤架饰以深棕色天然皮革细绳，造型灵感来源于古代日本武士刀的刀柄。可选配下方实木框架托盘与背漆玻璃台面，或升级为卡拉卡塔大理石版本，兼具功能与美感。

DUO 梳妆台是一件优雅精致、充满柔美气质的家具，专为现代女性日常护理仪式设计。采用实心白蜡木制作，提供Wengé（乌木色）或 Moka（摩卡色）饰面，延续整个系列有机柔和的设计线条。整体曲线优美，环抱着一面大尺寸可调节圆镜，左右配有两块嵌入式的小置物台，可选背漆玻璃或卡拉卡塔大理石材质。黄铜材质的精致五金细节，如侧置物台的金属隔件和镜面调节机构，彰显工艺品质。中央台面呈椭圆形，可选背漆玻璃或 Pelle Frau® 真皮包覆，满足不同审美和功能需求。

落时髦。饰面有鸡翅木、天然胡桃木及镶嵌胡桃木可选，赋予橱柜立体纹理质感。橱柜内侧选用枫木，与外侧的深色调对比鲜明。

由Ceccotti Collezioni制造的DUO Table共有四种款式,其设计简约而优雅,极简造型使其有着流畅干净的线条与蜿蜒柔软的曲线。坚固的底座采用鸡翅木色或摩卡色实心白蜡木制成,通过重塑而恢复了DUO咖啡桌的风格与设计。的确,桌腿由倾斜圆形截面的一大板组成,使用带有古铜色黄铜元件的十字扣件相互连接。底座支撑卡拉卡 塔大理石制成的桌面,可为矩形(250或292厘米)或圆形(直径150或180厘米)。DUO Table是Ceccotti Collezioni产 品目录中的第一款桌子,配有不带木质框架的开放式单板大理石桌面。珍贵的材料和功能性设计使DUO Table能够完美搭配不同空间与环境。

双搁架款或四搁架款DUO书柜以及DUO 书桌采用富有建筑感的设计风格，搁架可选用木材、彩绘玻璃或大理石材质，造型略显圆润，令配有交错立柱的白蜡木实木框架更显柔和。

DUO矮桌采用同样的建筑感廓形，有不同高度可选，搭配方形、矩形或圆形桌面。咖啡桌台面质感轻盈，置于具有包裹感的木质框架之上，搭配纤薄的宽桌腿，再现世纪中期咖啡桌的古典韵味。DUO流动储物柜采用双托盘设计，上层为玻璃托盘，下层托盘可选择木质、彩绘玻璃或大理石材质，饰以古铜色黄铜细节，让人联想起往昔豪华俱乐部和鸡尾酒吧的氛围，流露浪漫复古情调。DUO柱脚桌提供两种不同尺寸的圆形桌面，醒目的雕塑感底座饰以手工雕刻图案，令每张桌子都别具个性，成就美观的家居装饰方案。

DUO灯具可提供独立式照明解决方案，搭配乳白色倒锥形玻璃灯罩和罗纹装饰木质锥形灯杆，灵感源于1950年代意大利经典设计杰作中令人难忘的几何造型。

DUO屏风采用木质框架，四块隔板可选用壁纸或布艺装饰，极具个性定制风范，可灵活装点各种家居环境。DUO镜子包含一系列矩形、圆形或方形壁挂镜，配有染色白蜡木框架；DUO落地镜的框架以手工凿槽工艺打造，装饰别具匠心；这两款镜子令整个系列更臻完善。

本系列的主角是 DUO 床，这是一款现代设计风格的床，拥有柔和而温暖的造型。床身由四条倒“L”形的实心白蜡木腿支撑悬浮于地面，呼应了 DUO 储物柜和茶几的设计元素，优雅地重新诠释了该系列的特色。椭圆形截面且线条流畅的床框嵌入外扩的床头板中，床头板延伸至床架之外，营造出包裹感。灵感源自高端奢华皮具工艺的菱格绗缝图案，为整体设计增添了一丝精致优雅。斜切的装饰边勾勒出床的轮廓，纤细轻盈的侧腿更突显了整体的轻盈感和动感。整张床横向延展的比例强烈，个性鲜明，与整个系列完美呼应。

ZH
两大意大利知名品牌联手合作，由Roberto Lazzeroni担纲设计，开启联名合作系列的首个篇章。系列设计融合Poltrona Frau与Ceccotti Collezioni的品牌特质，展现两大品牌悠久传承的同时，亦彰显出双方对未来的共同畅想。

DUO系列的命名灵感源自两个独立元素相互融合的概念。这并非简单的个体相加，而是“以两种体验激发相同理念”。DUO系列保留了独立元素原本的特质，并通过协同创作为其增添个性。该系列巧妙融合回忆与创新这两个看似相悖的概念，在升华过往的同时开拓崭新当代视野，两者交织融汇，塑就精致典雅的系列作品。DUO系列的研发，从意大利甜蜜生活理念中汲取灵感，旨在颂扬无忧无虑、优雅自在的生活方式，让人尽享社交互动带来的愉悦之感。系列作品适合装点浪漫惬意的客厅，灵感源自五十年代的意大利“会客室”，当时正处于战后重建期，文化与创意领域一派繁荣景象。廓形满蕴复古气息，巧妙捕捉过往的时代精神；造型柔和百搭，比例拿捏精到，材质饰面品质优良，可灵活装点各类现代环境。

DUO沙发曲线优美且质感舒适，提供二人位沙发、二人位大沙发或弧形模块沙发组合等丰富款式，旨在营造社交氛围，让人们体会分享的愉悦。沙发配有可拆卸布艺套面或优雅皮革配布艺套面。沙发线条柔和，旨在致敬装饰艺术的浪漫情调，选用灵活的多层板结构，结合再生材质和精湛制造工艺，尽显现代魅力。

DUO Bench长凳是一项多功能解决方案,非常适合作为装饰元素作为放在桌子旁边或 用作床尾长凳。它的座椅更宽,几乎是之前型号的三倍。覆 面可采用Pelle Frau®皮革或布料。鸡翅木色或摩卡色实心白蜡木结构保持了特有的略微弯曲形状,以增加座椅的舒适度。

由Poltrona Frau设计 的**DUO Chair**,是一款带有软垫且线条蜿蜒包络的座椅。这款小扶手椅中的一切都传达出一种柔软 感,同时又充满活力:倾斜的后支腿为高靠背的椅子或横向扩展为两只欢迎“耳 朵”的小扶手椅赋予了生气。凸形座椅与 靠背的轻微凹形相辅相成,使其体积更具动感。饱满的垫充填料完全由Pelle Frau®皮革或 布料覆面,增加额外舒适度同时带来休闲互动的感觉。实心白蜡木支腿可采用鸡翅木色或摩卡色、原色或RAL漆面原色。

DUO扶手椅线条同样柔和大气，同时不失轻盈质感，这款扶手椅的白蜡木实木框架格外醒目，沿两侧一路延伸至支腿，与整体造型及纹理构成鲜明对比。DUO地毯甄选羊毛和桑蚕丝精制而成，饰以优雅几何图案，提供Poudre和Dusk Blue两种配色，与家具布艺套面的色调相得益彰。

DUO橱柜为储物橱柜，有三种款式可选：高柜、配有单门置物篮的双门矮柜、配有双门置物篮的双门矮柜。该设计重新演绎1950年代的经典餐具柜：底座和橱柜之间以隔板隔开，令优雅的实木结构更添轻盈之感，作品外观更显利

marbre Calacatta 或 在 玻璃 漆面 (或 在 枫木 漆面) 的 结构) , 嵌 入 而 不 有 解 决 方 案 的 连 续 性 。

Objet poétique et en même temps extrêmement fonctionnel, le **Miroir Triptyque DUO** évoque l'atmosphère sophistiquée d'un atelier de haute couture. Réalisé avec des miroirs insérés dans un cadre en frêne massif, il permet, une fois ouvert, de se mirer confortablement sous différents angles. Lorsqu'il n'est pas utilisé, les deux volets latéraux peuvent être rapprochés, créant l'effet d'une porte fermée grâce au raffiné revêtement extérieur en frêne cannelé. Il peut être fixé au mur grâce à un mécanisme d'ancrage à baïonnette.

Le valet de nuit, né au XVIIIe siècle comme complément de support pour les convives, devient un élégant porte-vêtements, parfait pour la chambre à coucher moderne. Réalisé en bois massif de frêne, il a une structure à trois pieds composée d'un montant arrière qui se divise en V et soutient un cintre, et de deux montants avant qui soutiennent un porte-pantalon légèrement courbé, enrichi d'un cordon en cuir naturel couleur marron foncé, dont la ligne rappelle la forme (qui évoque la poignée) d'une ancienne katana japonaise. Il est disponible avec une étagère inférieure encadrée en bois massif et un dessus en verre laqué, ou dans la version avec dessus en marbre Calacatta.

La **Coiffeuse DUO** est un meuble élégant et raffiné, au caractère délicatement féminin, pensé pour les rituels quotidiens de soin de soi. Réalisée en bois massif de frêne avec finition Wengé ou Moka, elle présente les lignes organiques typiques communes à toute la collection. Sa délicate silhouette courbe encadre un grand miroir rond inclinable, flanqué de deux petites étagères encastrées à fleur et réalisées en verre laqué ou en marbre Calacatta. Les détails métalliques raffinés, tels que les entretoises des petites étagères latérales et le mécanisme de réglage du miroir, sont réalisés en laiton massif. L'étagère centrale a une forme elliptique et peut être en verre laqué ou revêtu en cuir Pelle Frau®.

Le **Commode DUO** est née du classique "semainier" dédié au changement de tenue quotidien, et le réinterprète en se transformant en un élégant contenant à la ligne élancée. Elle présente six tiroirs spacieux et un petit compartiment ouvert, enrichi d'une lumière LED avec commande tactile qui illumine délicatement l'intérieur. Dans le compartiment ouvert, un tiroir coulissant peut être inséré, revêtu en Pelle Frau® et divisé en quatre compartiments. Le socle et le cadre sont réalisés en bois massif de frêne, et la commode peut avoir une finition extérieure sur tous les côtés en ébène ou en noyer, noyer incrusté, érable ou incrusté. Cette dernière finition enrichit l'esthétique globale grâce à un jeu sophistiqué de textures qui alterne le dessin naturel du bois avec des découpes verticales de grand impact visuel. Le détail final de grande raffinement est le dessus en

Le protagoniste de la collection est le **Lit DUO**, un lit au design contemporain, caractérisé par des formes douces et accueillantes. Suspendu du sol sur quatre pieds en frêne massif en forme de "L" inversé - un clin d'œil au meuble et à la table basse DUO - il réinterprète avec élégance certains éléments distinctifs de la collection. Le cadre du lit, à section elliptique et au profil effilé, s'emboîte dans la tête de lit saillante, qui s'étend au-delà de la structure pour créer un effet enveloppant. Le motif matelassé, inspiré des travaux haut de gamme de la maroquinerie de luxe, ajoute une touche d'élégance sophistiquée. Un bord décoratif biseauté délimite le profil du lit, tandis que les pieds latéraux, fins et légers, en accentuent la dynamique. Le résultat est un lit au caractère affirmé, avec une présence horizontale marquée, parfaitement en équilibre avec le reste de la collection.

Lit DUO

Lit DUO

Lit DUO

Lit DUO

Lit DUO

Lit DUO

Lit DUO

Lit DUO

Lit DUO

Lit DUO

Lit DUO

Lit DUO

Lit DUO

Lit DUO

Lit DUO

Lit DUO

Lit DUO

Lit DUO

Lit DUO

Lit DUO

Lit DUO

Lit DUO

Lit DUO

Lit DUO

Lit DUO

Lit DUO

Lit DUO

Lit DUO

Lit DUO

Lit DUO

Lit DUO

Lit DUO

Lit DUO

Lit DUO

Lit DUO

Lit DUO

Lit DUO

Lit DUO

Lit DUO

Lit DUO

Lit DUO

Lit DUO

Lit DUO

Lit DUO

Lit DUO

Lit DUO

Lit DUO

Lit DUO

Lit DUO

Lit DUO

Lit DUO

DUO Bed — Bed

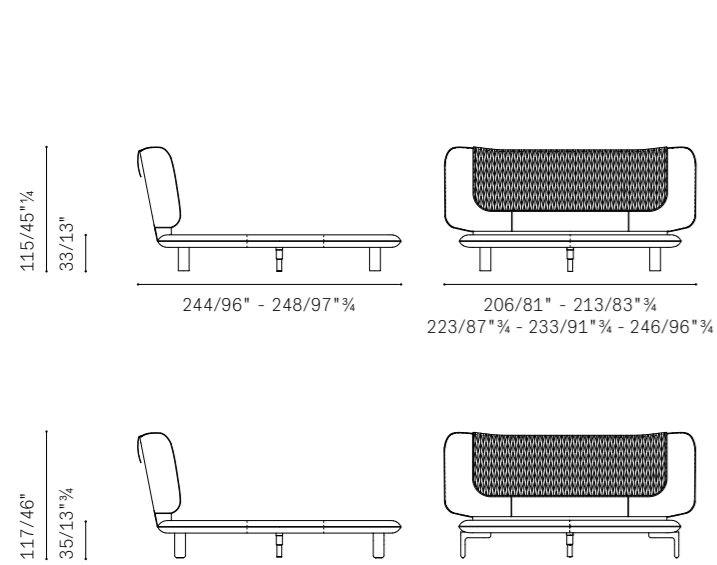

DUO Bed — Finishes

Feet.

- Aluminum cylindrical feet covered in Pelle Frau® leather to match the bed
- (Optional at an extra cost) Solid wood feet, available in the following finishes:
 - Ash wood in a Wenge stain
 - Ash wood in a Moka stain

Upholstery. In Pelle Frau® leather:

- ColorSphere® (SC)
- Nest

Note: The two-tone option between the bed and the decorative quilt incurs a 5% surcharge compared to the selected leather category price.

Removability: Not available.

Headboard Back: Available with a covering in:

- Fabric (Poltrona Frau Jacquard fabric)
- Leather (matching the upholstery)

DUO Bedside Table — Bedside Table 57×42 h53

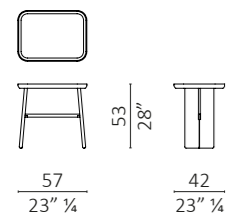

DUO Bedside Table — Bedside Table with shelf 57×42 h53

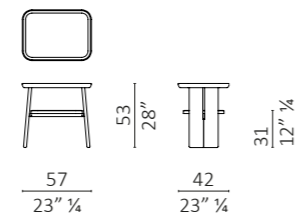

Please note:
this catalogue shows only some technical drawings, in order
to know all the availabilities please refer to the current price list.

DUO Bedside Table — Bedside Table with drawer 57×42 h53

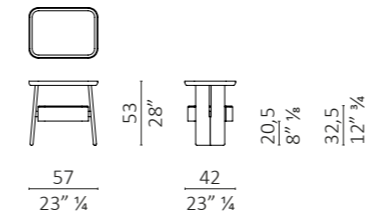

DUO Bedside Table — Finishes

Dimensions:

- 57×42h53
- with shelf 57×42 h53
- with drawer 57×42 h53

Structure and shelf frame. In solid wood:

- Ash in a Wenge stain
- Ash in a Moka stain

Top:

- Ash in a Wenge or Moka stain (same finish as the one chosen for the structure)
- semi-gloss Calacatta marble
- coloured glass
- (SC) leather

The DUO Bedside table with drawer can have a leather lining.

DUO Bench — Bench

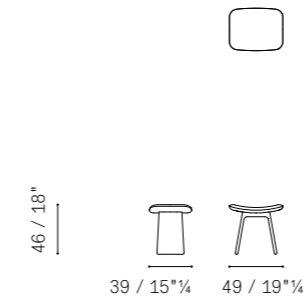

DUO Bench — Bench Large

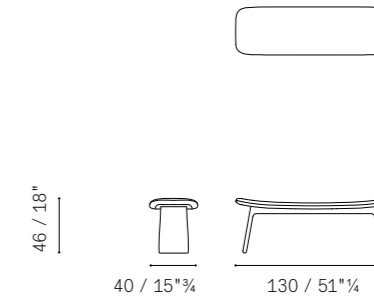

DUO Bench — Finishes

Structure. In solid wood:

- Ash in a Wenge stain
- Ash in a Moka stain

Upholstery. Entirely in Pelle Frau® leather or fabric.

- ColorSphere® (SC)
- Heritage
- Nest
- Soul
- Natural leather
- Velvety
- Fabric A
- Fabric B
- Fabric C
- C.O.M.

DUO Bookcase — Bookcase 160×45 h160

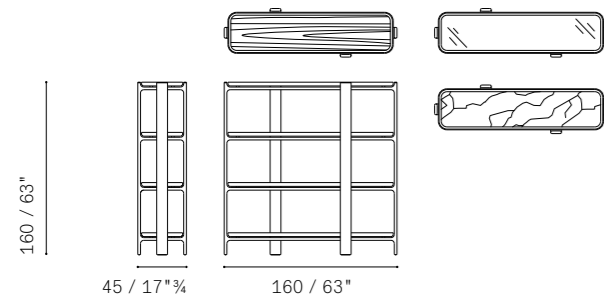

DUO Bookcase — Bookcase 160×45 h60

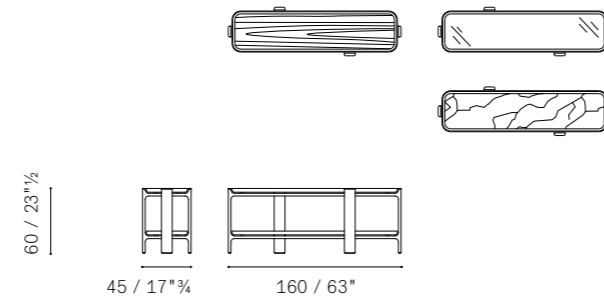

DUO Bookcase — Finishes

Dimensions:

- 160×45 h160 cm
- 160×45 h60 cm

Structure and shelf frame. In solid wood:

- Ash in a Wenge stain
- Ash in a Moka stain

Top:

- Ash in a Wenge or Moka stain (same finish as the one chosen for the structure)
- Coloured glass
- Semi-gloss Calacatta marble

Aesthetic details. The bookcase can have shelves with different finishes

DUO Cabinet — High cabinet

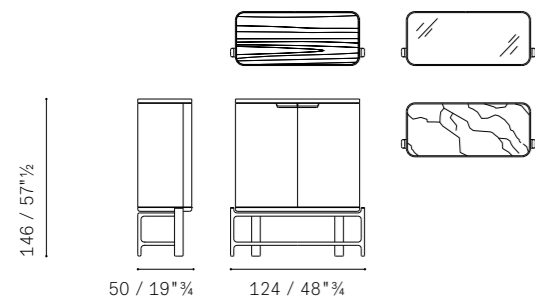

DUO Cabinet — Low cabinet 249×50 h91

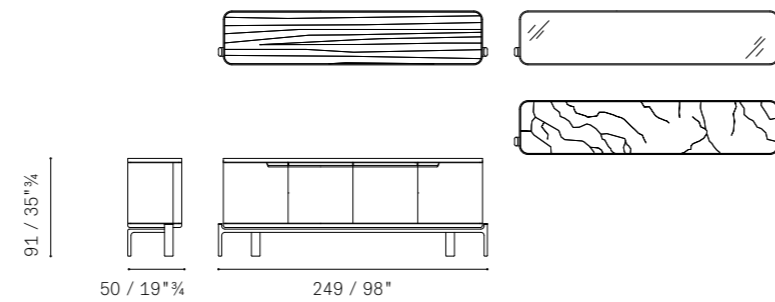

Please note:

this catalogue shows only some technical drawings, in order to know all the availabilities please refer to the current price list.

DUO Cabinet — Low cabinet 189×50 h91

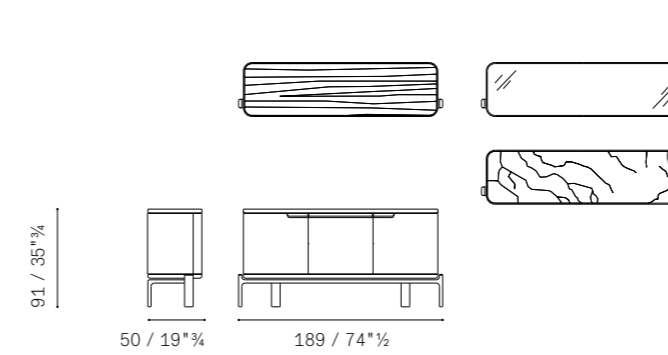

DUO Cabinet — Finishes

Dimensions:

- High Cabinet 124×50 h 146 cm
- Low Cabinet 189×50 h 91 cm
- Low Cabinet 249×50 h 91 cm

Structure and shelf frame. In solid wood:

- Ash in a Wenge stain
- Ash in a Moka stain

External part of cabinets in:

- Ebony
- Natural walnut
- Inlaid walnut

Top:

- Ash in a Wenge or Moka stain (same finish as the one chosen for the structure)
- Semi-gloss Calacatta marble
- Coloured glass

DUO Chair — Chair

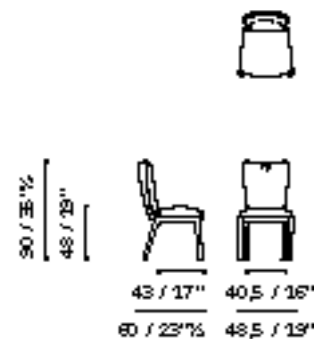

DUO Chair — Small armchair

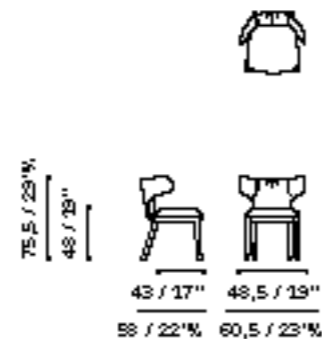

DUO Chair — Chair

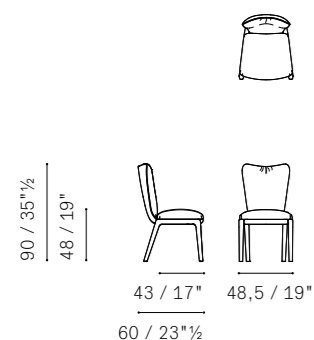

DUO Chair — Small armchair

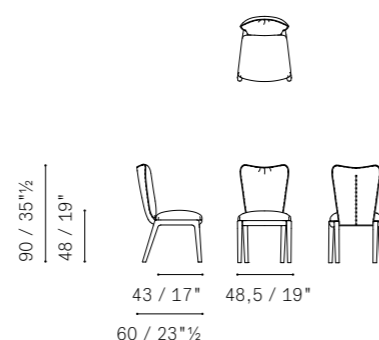

DUO Chair — Chair

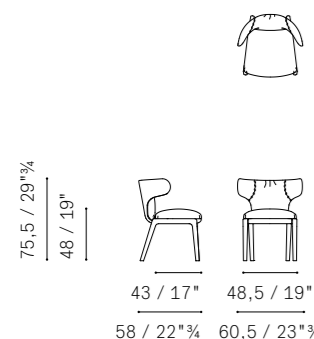

DUO Chair — Finishes

Base. Consists of four legs made of solid Ash wood with triangular section.

Leg finishes.

- Ash wood in a Wenge stain
 - Ash wood in a Moka stain
- Additional special finishes with surcharge:
- Custom stained Ash
 - RAL lacquered Ash to sample.

Upholstery. In Pelle Frau® leather or fabric:

- ColorSphere® (SC)
- Nest
- Soul
- Fabric A
- Fabric B
- Fabric C
- C.O.M.

Removability. Not provided.

DUO Chair — Small armchair

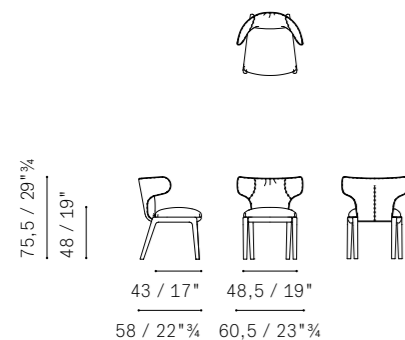

Please note:
this catalogue shows only some technical drawings, in order
to know all the availabilities please refer to the current price list.

DUO Chest of Drawers — Chest of Drawers

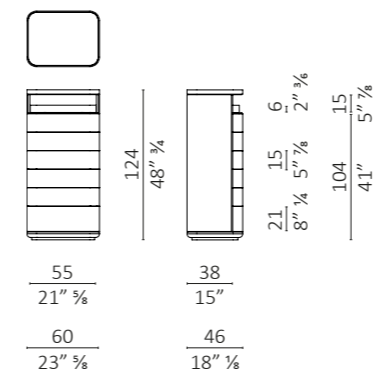

DUO Chest of Drawers — Finishes

Structure and shelf frame. In solid wood:

- Ash in a Wenge stain
- Ash in a Moka stain

Top:

- Ash in a Wenge or Moka stain (same finish as the one chosen for the structure)
- semi-gloss Calacatta marble
- coloured glass

External part in:

- American walnut
- inlaid American walnut
- maple
- inlaid maple
- ebony

The DUO chest of drawer can have up to 6 leather lining and a sliding tray in Ash or (SC) leather.

DUO Console — Console 160x45 h90

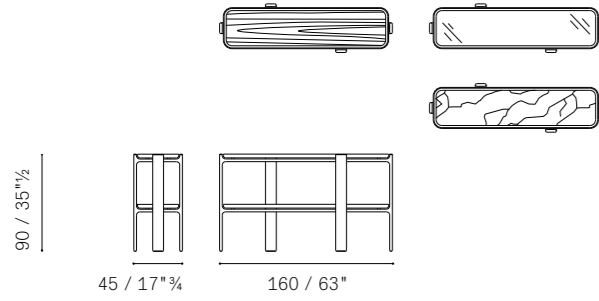

DUO Console — Finishes

Structure and shelf frame. In solid wood:

- Ash in a Wenge stain
- Ash in a Moka stain

Top:

- Ash in a Wenge or Moka stain (same finish as the one chosen for the structure)
- Coloured glass
- Semi-gloss Calacatta marble

Aesthetic details. The console can have shelves with different finishes

DUO Floor Mirror — Floor Mirror

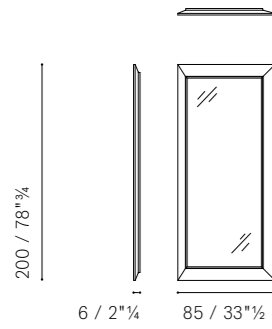

DUO Floor Mirror — Finishes

Frame. In solid wood:

- Ash in a Wenge stain
- Ash in a Moka stain

DUO Lamp — Floor lamp

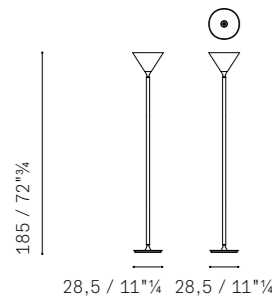

DUO Lamp — Finishes

Structure. In solid wood:

- Ash in a Wenge stain
- Ash in a Moka stain

Certifications:

- EU/EXTRA EU
- USA

Please note:
this catalogue shows only some technical drawings, in order
to know all the availabilities please refer to the current price list.

DUO Lounge — Armchair

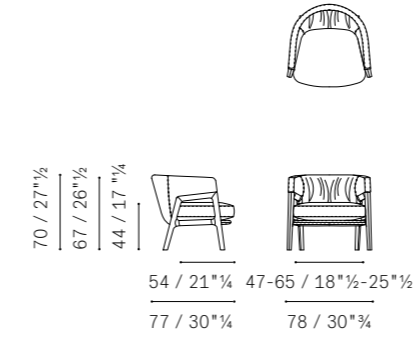

DUO Lounge — Finishes

Base finish. In solid wood:

- Ash in a Wenge stain
- Ash in a Moka stain

Upholstery. Entirely in Pelle Frau® leather or fabric.

- ColorSphere® (SC)
- Nest
- Soul
- Velvety
- Fabric A
- Fabric B
- Fabric C
- C.O.M.

Removability. Only for the seat cushion with leather and fabric cover.
Aesthetic details. The stitching is tone-on-tone.

DUO Low Table — Coffee table ø57 h36

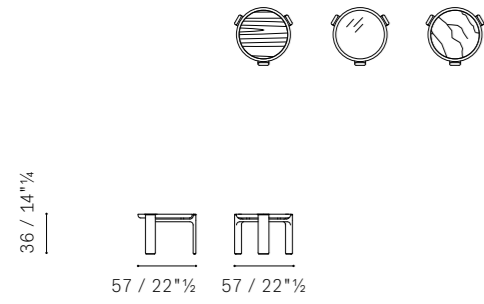

DUO Low Table — Coffee table ø57 h50

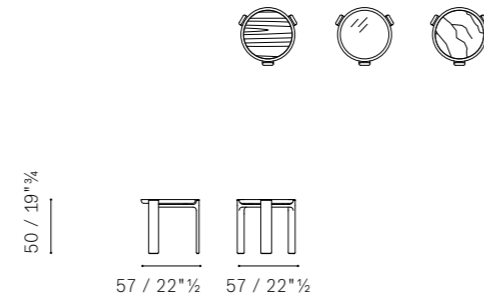

DUO Low Table — Coffee table ø80 h36

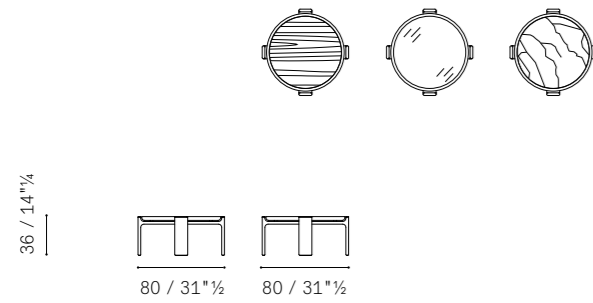

DUO Low Table — Coffee table ø120 h36

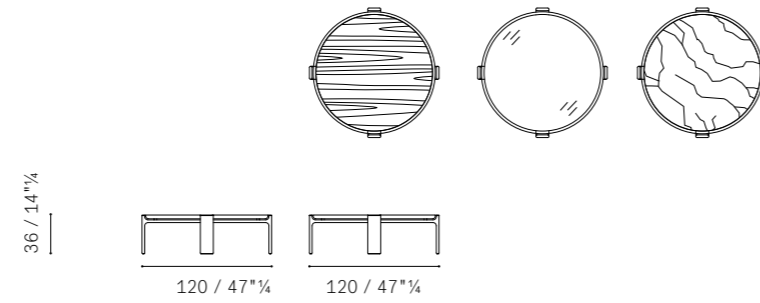

DUO Low Table — Coffee table total marble ø80 h36

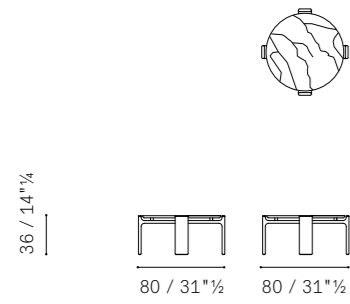

DUO Low Table — Coffee table total marble ø120 h36

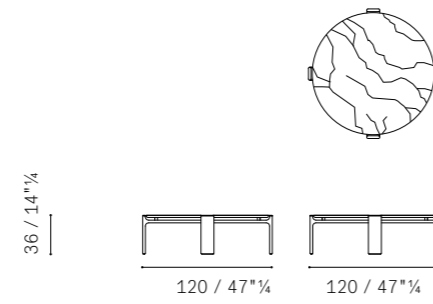

DUO Low Table — Coffee table 90×90 h36

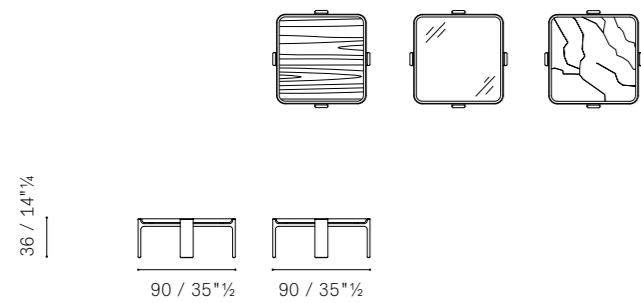

DUO Low Table — Coffee table 120×120 h36

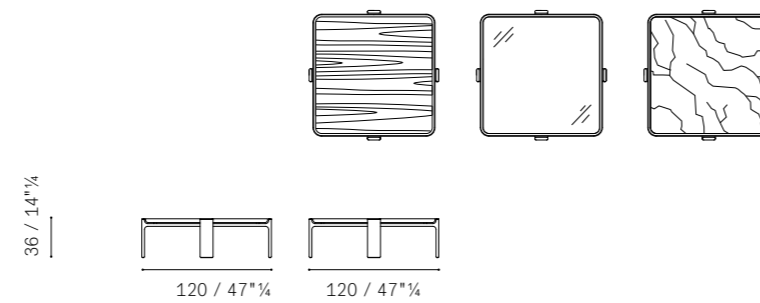

Please note:
this catalogue shows only some technical drawings, in order
to know all the availabilities please refer to the current price list.

DUO Low Table — Coffee table 140×90 h36

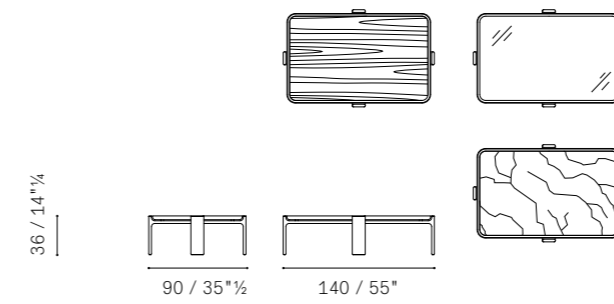

DUO Low Table — Coffee table total marble 140×90 h36

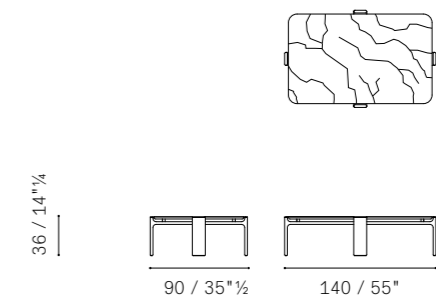

DUO Low Table — Coffee table total marble 90×90 h36

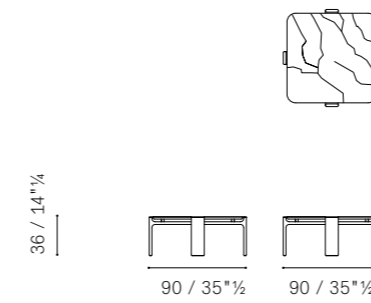

DUO Low Table — Coffee table total marble 120×120 h36

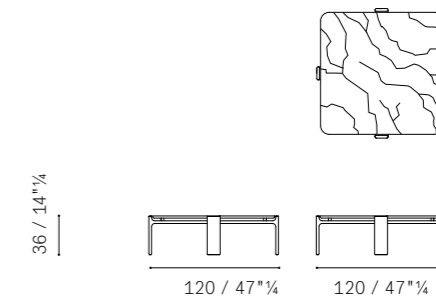

DUO Low table — Finishes

- Dimensions:**
- ø 57 h 36
 - ø 57 h 50
 - ø 80 h 36 | ø 80 h 36 Total Marble
 - ø 120 h 36 | ø 120 h 36 Total Marble
 - 90×90 h 36 | 90×90 h 36 Total Marble
 - 120×120 h 36 | 120×120 h 36 Total Marble
 - 140×90 h 36 | 140×90 h 36 Total Marble

Structure and shelf frame. In solid wood

- Ash in a Wenge stain
- Ash in a Moka stain

Top:

- Ash in a Wenge or Moka stain (same finish as the one chosen for the structure)
- Semi-gloss Calacatta marble
- Coloured glass
- Total semi-gloss Calacatta marble (not available in the ø 57 size)

Aesthetic details.

In the Total Calacatta marble version there is no solid Ash frame.

DUO Mirror — Mirror $\varnothing 113 \times 3,5$

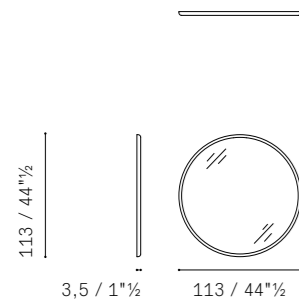

DUO Mirror — Mirror $\varnothing 73 \times 3,5$

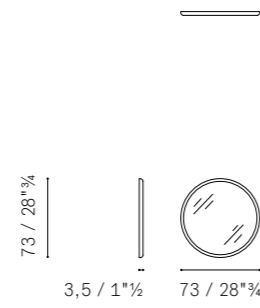

DUO Mirror — Mirror $\varnothing 50 \times 3,5$

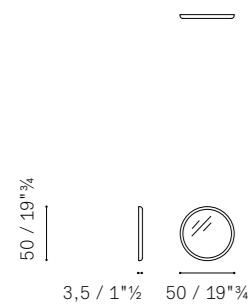

DUO Mirror — Mirror $83 \times 3,5$ h83

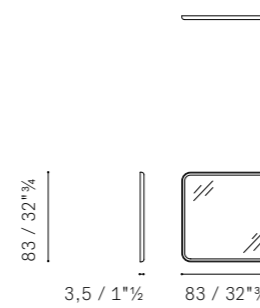

DUO Mirror — Mirror $113 \times 3,5$ h113

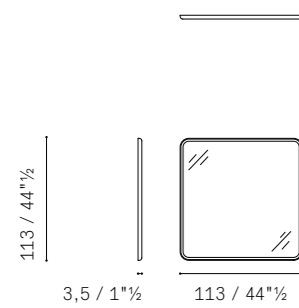

DUO Mirror — Mirror $113 \times 3,5$ h83

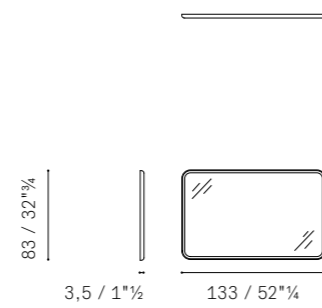

DUO Mirror — Finishes

Dimensions:

- $113 \times 3,5$ h 113 cm
- $83 \times 3,5$ h 83 cm
- $133 \times 3,5$ h 83 cm
- D113 W 3.5 cm
- D73 W 3.5 cm
- D50 W 3.5 cm

Frame. In solid wood:

- Ash in a Wenge stain
- Ash in a Moka stain

Please note:
this catalogue shows only some technical drawings, in order
to know all the availabilities please refer to the current price list.

DUO Pedestal Table — Coffee table $\varnothing 80$ h41

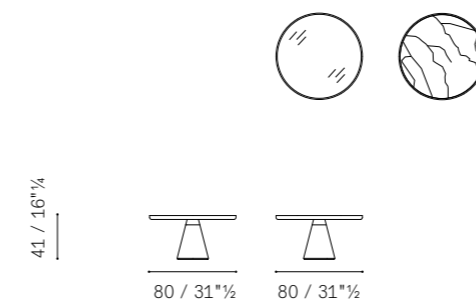

DUO Pedestal Table — Coffee table $\varnothing 50$ h55

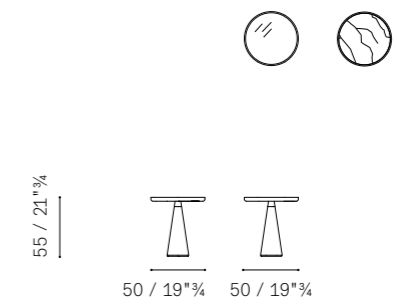

DUO Pedestal Table — Finishes

Dimensions:

- $\varnothing 50$ h 55
- $\varnothing 80$ h 41

Structure and top frame. In solid wood

- Ash in a Wenge stain
- Ash in a Moka stain

Top:

- Semi-gloss Calacatta marble
- Coloured glass

DUO Rug — Rug 300×200 cm

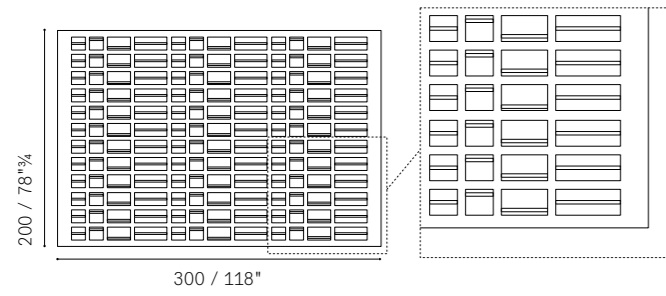

DUO Rug — Finishes

Dimensions:
- 200×300 cm
- 250×350 cm

Colours:
- Dusk Blue
- Poudre

Technique. Rug entirely hand-knotted on wooden looms with an Indo-Tibetan knot.

Quality. 86,000 knots/m²

Overall composition (structure and surface). 80% wool + 20% natural silk.

Aesthetic details. All the carpet collections are marked with a hand-sewn leather label with the Poltrona Frau trademark embossed.

Sustainably. Made in India.

DUO Rug — Rug 350×250 cm

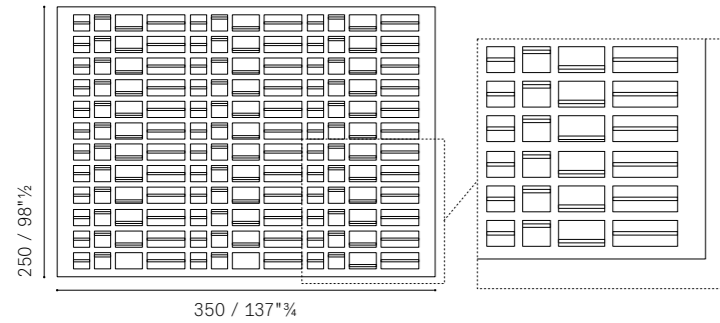

DUO Screen — Room divider 4 modules

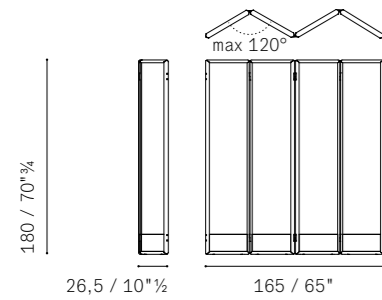

DUO Screen — Room divider 5 modules

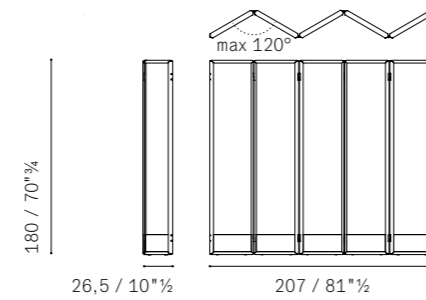

DUO Screen — Room divider 3 modules

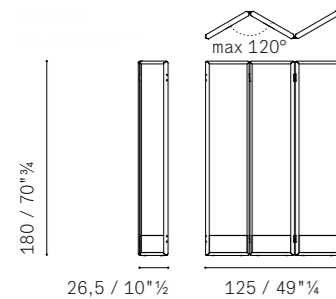

DUO Screen — Finishes

Structure. In solid wood:
- Ash in a Wenge stain
- Ash in a Moka stain

Covering. A hollow panel covered in wallpaper:
- Puro
- Canvas

Aesthetic details. The front and rear of the panel can be covered with different finishes.

Please note:
this catalogue shows only some technical drawings, in order to know all the availabilities please refer to the current price list.

DUO Sofa — 2-seater sofa

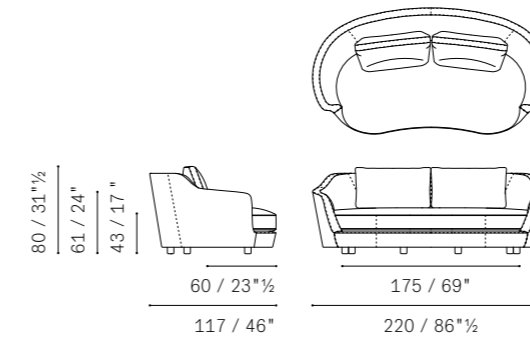

DUO Sofa — 3-seater sofa with 3 cushion 50×70 cm

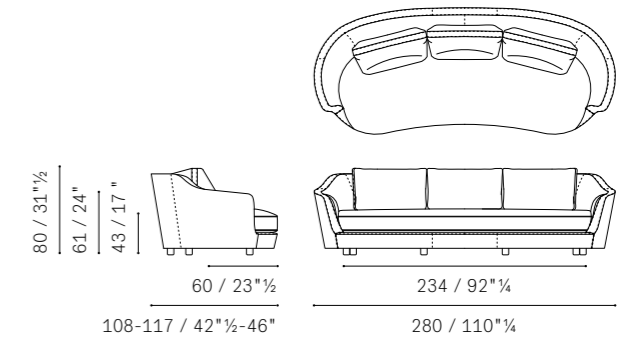

DUO Sofa — 3-seater sofa with 2 cushion 100×50 cm

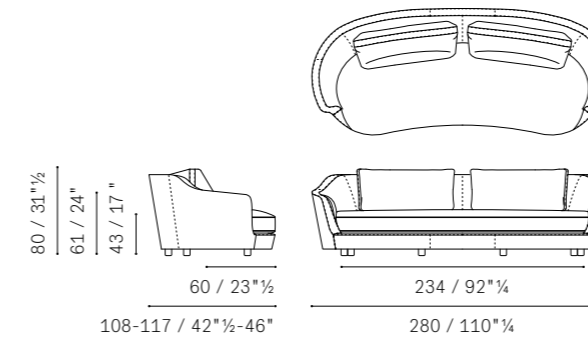

DUO Sofa — Curved terminal armchair with bench

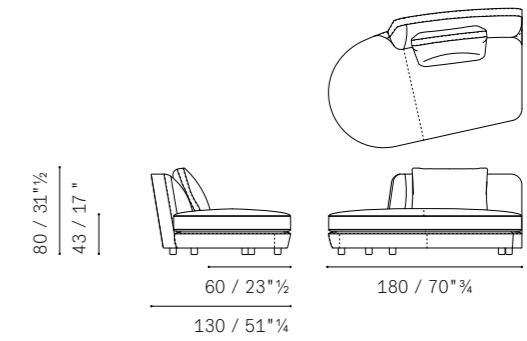

DUO Sofa — Curved sectional 2-seater sofa

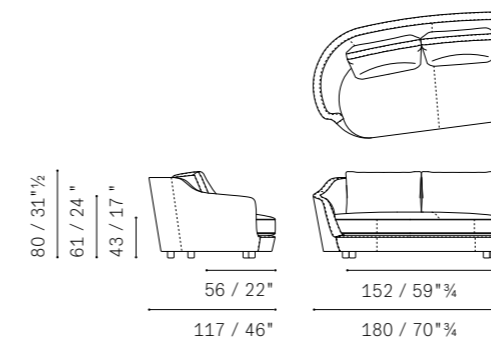

DUO Sofa — Curved sectional armless 2-seater sofa

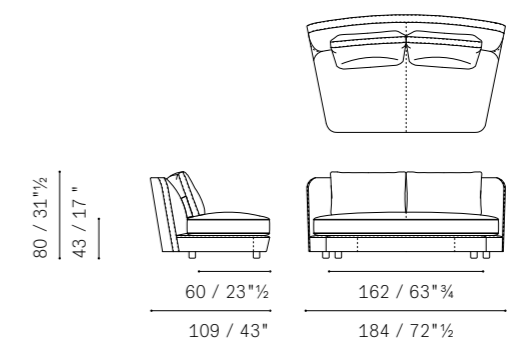

DUO Sofa — 60° corner module

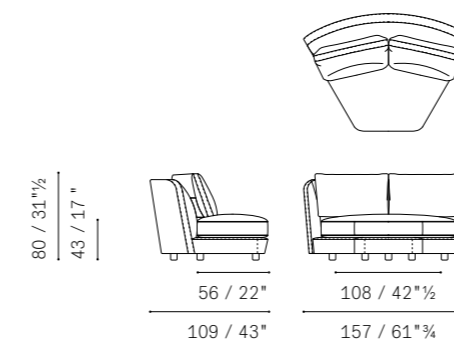

DUO Sofa — Curved large sectional chaise-longue

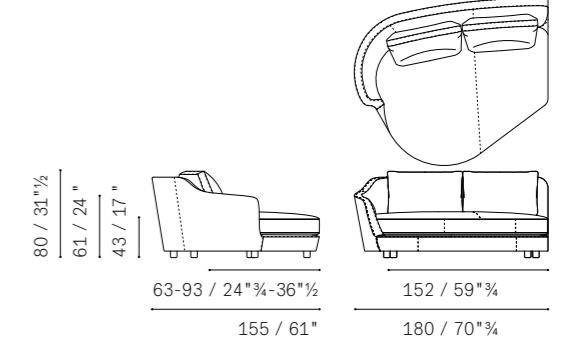

DUO Sofa — Composition 1

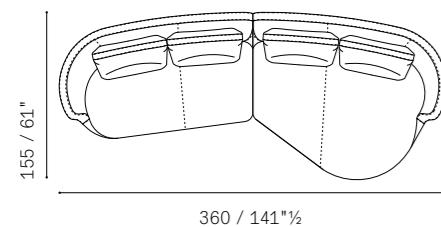

DUO Sofa — Composition 2

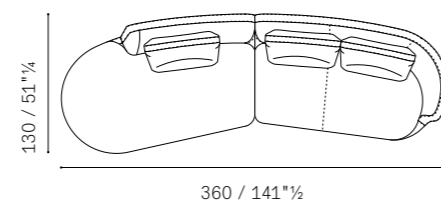

DUO Sofa — Composition 3

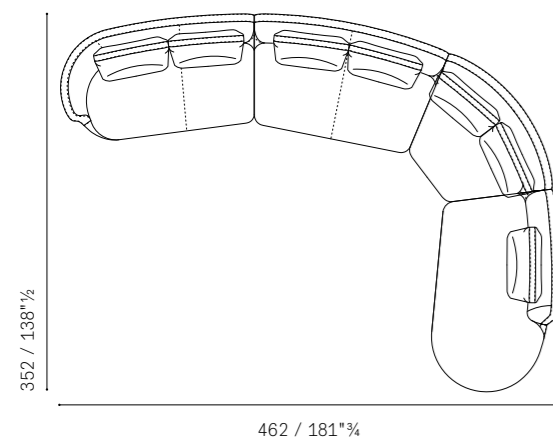

DUO Sofa — Finishes

- Upholstery:**
- ColorSphere®
 - ColorSphere®/Fabric A
 - ColorSphere®/Fabric B
 - ColorSphere®/Fabric C
 - ColorSphere®/C.O.M
 - Nest
 - Nest/Fabric A
 - Nest/Fabric B
 - Nest/Fabric C
 - Nest/C.O.M
 - Soul
 - Soul/Fabric A
 - Soul/Fabric B
 - Soul/Fabric C
 - Soul/C.O.M
 - Velvety
 - Fabric A
 - Fabric B
 - Fabric C
 - C.O.M

Removability. The fabric upholstery is totally removable. The leather upholstery is removable only for the seat cushions and backrest.

Aesthetic details. Stitching are tone-on-tone.

Feet.

- Cylindrical Ø60 mm in black anodized aluminium
- (OPTIONAL WITH SURCHARGE) knife shaped in satin-burnished aluminium.

Please note:
this catalogue shows only some technical drawings, in order to know all the availabilities please refer to the current price list.

DUO Table — 110×250 h75

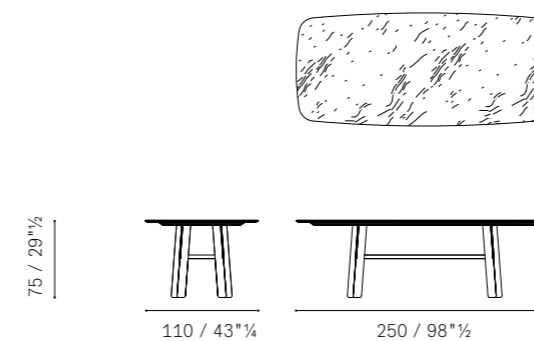

DUO Table — 110×292 h75

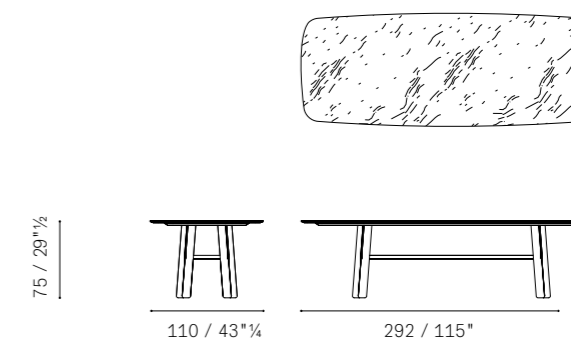

DUO Table — ø 150 h75



DUO Table — ø 180 h75

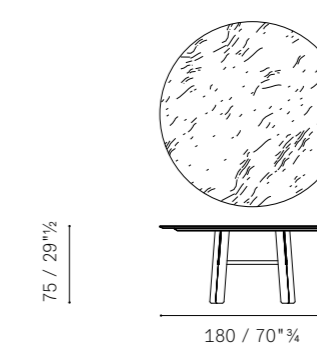

DUO Table — Finishes

Versions.

- ø 150 h 75
- ø 180 h 75
- 250×110 h 75
- 292×110 h 75

Base. Made of solid Ash wood, available in the following finishes:

- Ash wood in a Wenge stain
- Ash wood in a Moka stain

Top. Crafted from a single slab of marble with rounded corners and tapered edges:

- Semi-brilliant Calacatta marble
- Semi-brilliant Arabescato marble

Subtop. Additional stability is provided by a black-painted MDF subtop connected to the base with special steel plates.

Metal details. Connection elements and metallic finishing details are made of brushed bronzed brass.

DUO Triptych Mirror — Mirror

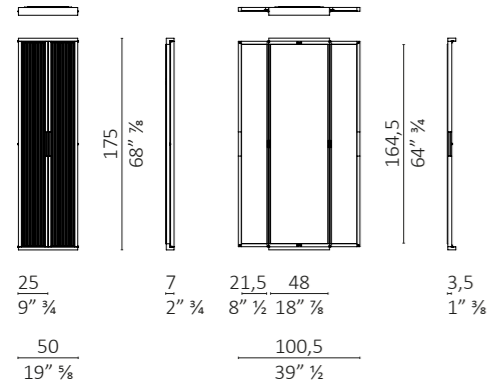

DUO Triptych Mirror — Finishes

Structure. In solid wood:
 -Ash in a Wenge stain
 -Ash in a Moka stain

DUO Trolley — Trolley

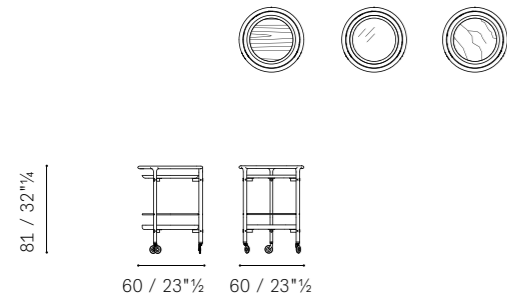

DUO Trolley — Finishes

Structure. In solid wood
 - Ash in a Wenge stain
 - Ash in a Moka stain

Upper top in glass:
 - Transparent
 - Bronzed
 - Smoked

Lower top:
 - Ash in a Wenge or Moka stain (same finish as the one chosen for the structure)
 - Coloured glass
 - Semi-gloss Calacatta marble

DUO Valet Stand — Valet Stand 61×42 h112,5

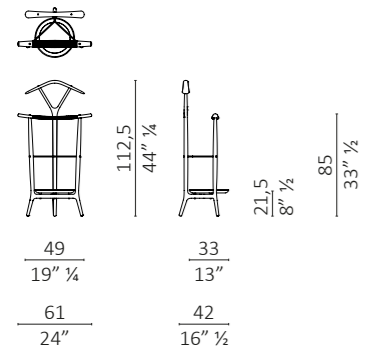

DUO Valet Stand — Valet Stand total marble 61×42 h112,5

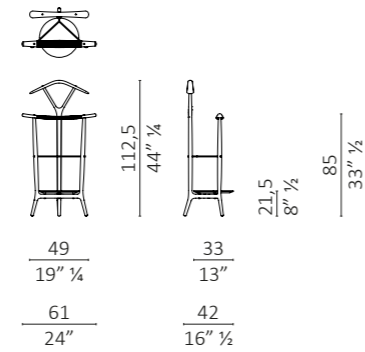

DUO Valet Stand — Finishes

Structure and shelf frame. In solid wood:
 -Ash in a Wenge stain
 -Ash in a Moka stain

Top:
 -Coloured glass
 - Total semi-gloss Calacatta marble *

* Please note: In the Total Calacatta marble version there is no solid Ash frame.

Leather cord in natural leather 201 Testa di Moro.

Please note:
 this catalogue shows only some technical drawings, in order to know all the availabilities please refer to the current price list.

DUO Vanity — Vanity Desk 105×58,5 h130

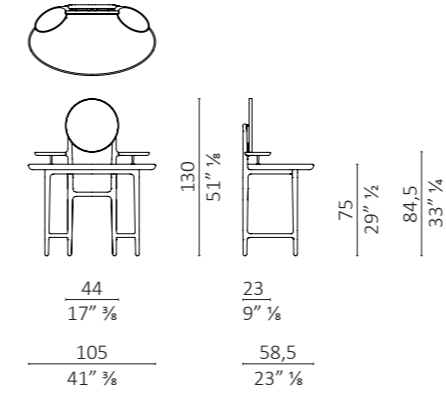

DUO Vanity — Finishes

Structure and shelf frame. In solid wood:
 -Ash in a Wenge stain
 -Ash in a Moka stain

Top:
 - coloured glass
 - (SC) leather

Shelves:
 - coloured glass
 - semi-gloss Calacatta marble

CONTACTS

Poltrona Frau S.p.A

a socio unico
Sede legale in Meda (MB)
Via Luigi Busnelli 1
20821 Italy

Sede operativa in Tolentino (MC)
Via Sandro Pertini 22
62029 Italy

Tel. +39 0733 909.1
Fax +39 0733 971600

www.poltronafrau.com

CREDITS

Project commissioned by the
Marketing & Communications
dept. of Poltrona Frau spa

Graphic design
studio FM milano

Creative direction
K-448

Styling
Sarah de Beaumont

Lifestyle CGI Photography
Fuorifuoco Agency

Still-life Photography
Alessio D'Aniello
Mario Ciampi

Post production / Color selection
Pan Group Milano

Printing
OGM Padova

© POLTRONA FRAU 2025

Poltrona Frau reserves the right to modify the products and the components in this price list, without any prior notice. Company with certified Quality Management System in accordance with ISO 9001, certified Environmental Management System in accordance with ISO 14001, certified Occupational Health and Safety Management System in accordance with BS OHSAS 18001, certified Chain of Custody System in accordance with Forest Stewardship Council® FSC-STD-40-004 (FSC-C153281).

Company subject to management and co-ordination of Haworth Italy Holding S.r.l.

