

CECCOTTICOLLEZIONI

*Teahouse*  
Stories of gestures



CECCOTTICOLLEZIONI

*Teahouse*  
Stories of gestures





## Stories of gestures

Ceccotti Collezioni explores the beauty and deep meaning of everyday gestures. A sense of intimacy and connection with the past emerges in the repetition of simple, often unnoticed actions. Each ritual, from the most ordinary to the most refined, becomes an act of love towards oneself and others, capable of transforming fleeting moments into meaningful experiences. The objects that accompany these gestures take on symbolic value, becoming the bearers of memories and bridges to forgotten emotions.

Ceccotti Collezioni esplora la bellezza e il significato profondo dei gesti nella quotidianità. Attraverso azioni semplici e ripetute, spesso inosservate, emerge un senso di intimità e connessione con il passato. Ogni rituale, dal più ordinario al più curato, diventa un atto d'amore verso sé stessi e gli altri, capace di trasformare momenti fugaci in esperienze ricche di significato. Gli oggetti che accompagnano questi gesti si caricano di valore simbolico, diventando custodi di memorie e ponti verso emozioni dimenticate.









*Teahouse* collection  
designed by Christophe Pillet

“Gestures repeated day after day are an act of connection with oneself and with time. They bring a sense of peace, a way to embrace the past with gratitude and face the future with serenity. The beauty of these objects lies in their simplicity, in how they blend the tangible and intangible, creating a sense of harmony that comforts the soul and celebrates life”.

“I gesti, ripetuti giorno dopo giorno, sono un atto di connessione con sé stessa e con il tempo. Portano un senso di pace, un modo per abbracciare il passato con gratitudine e affrontare il futuro con serenità. La bellezza di questi oggetti sta nella loro semplicità, nel modo in cui intrecciano il tangibile con l’intangibile, creando un’armonia che scalda l’anima e celebra la vita.”

The collection was born from an encounter with Christophe Pillet and the desire to imagine a scenario together dedicated to the art of tea service and its rituals—giving life to a narrative shaped by the poetry of the gestures that accompany it. The result is a lounge setting composed of various elements, including a chair, a table, and a selection of cabinets, such as a console with drawers and an elegant storage unit.

*Teahouse* is a sophisticated and elegant collection, crafted from sections of solid wood reduced to its purest essence. Each piece is distinguished by a minimalist aesthetic, defined by a striking crossed graphic element that disrupts the parallelism of the shapes. The chiasmus between the uprights of the structures is not only a refined aesthetic detail, but also serves as a symbol of connection, giving depth and harmony to the design.

La collezione nasce dall’incontro con Christophe Pillet e dal desiderio di immaginare insieme uno scenario dedicato al servizio del tè, dando vita a un racconto scandito dalla poesia dei gesti che lo accompagnano. Il risultato è un’ambientazione lounge che comprende diversi elementi, tra cui una sedia, un tavolo e una serie di cabinet, tra cui una console con cassetti e un raffinato contenitore.

*Teahouse* è una collezione sofisticata ed elegante, realizzata con sezioni di legno massello ridotte al minimo essenziale. Gli oggetti si distinguono per un’estetica minimale, definita da un segno grafico incrociato che interrompe il parallelismo delle forme. Il chiasmo tra i montanti delle strutture non è solo un dettaglio estetico raffinato, ma diventa un simbolo di connessione, conferendo profondità e armonia al design.





INTIMACY

ESSENCE

tea ceremony

SELECTION

WARMTH

















FLOW

COMPOSITION

Art of painting

RESONANCE



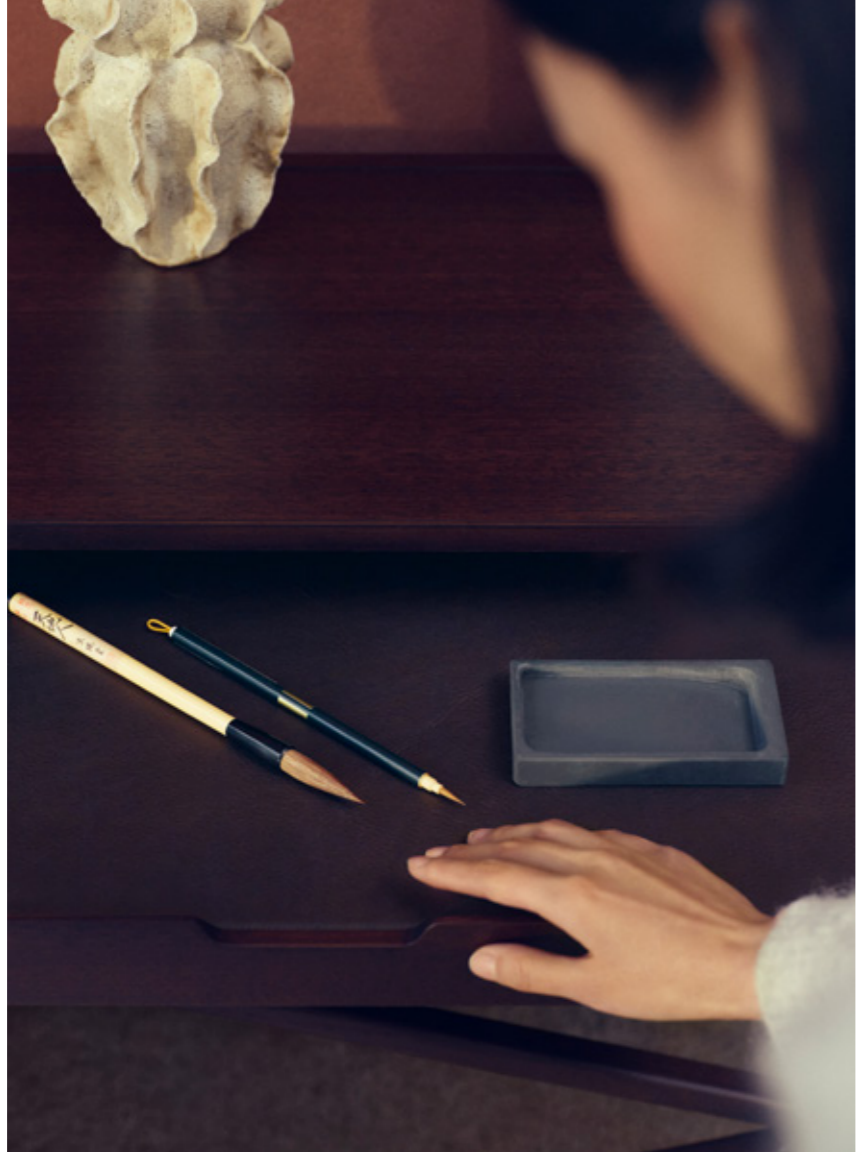







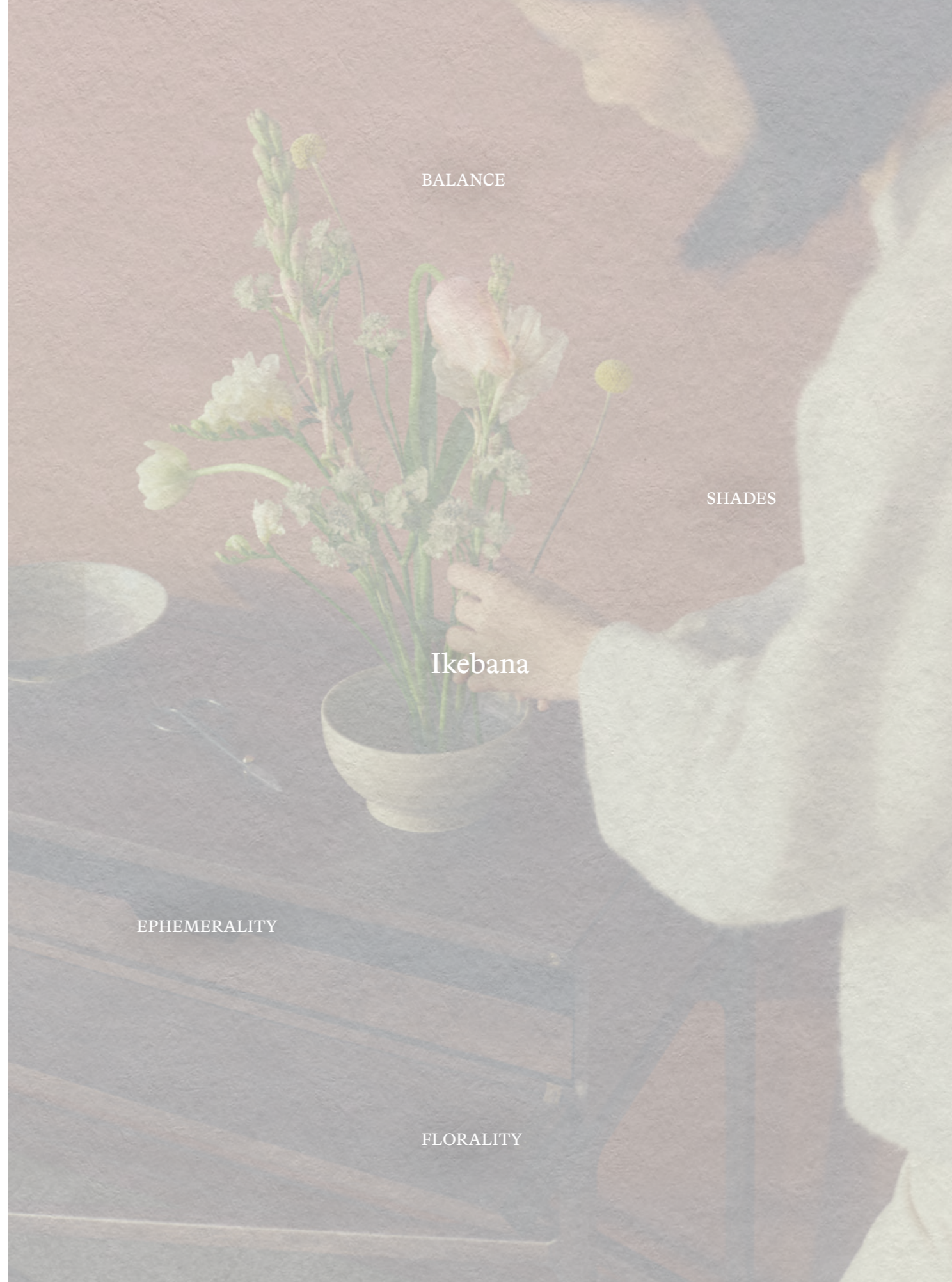

BALANCE

SHADES

Ikebana

EPHEMERALITY

FLORALITY







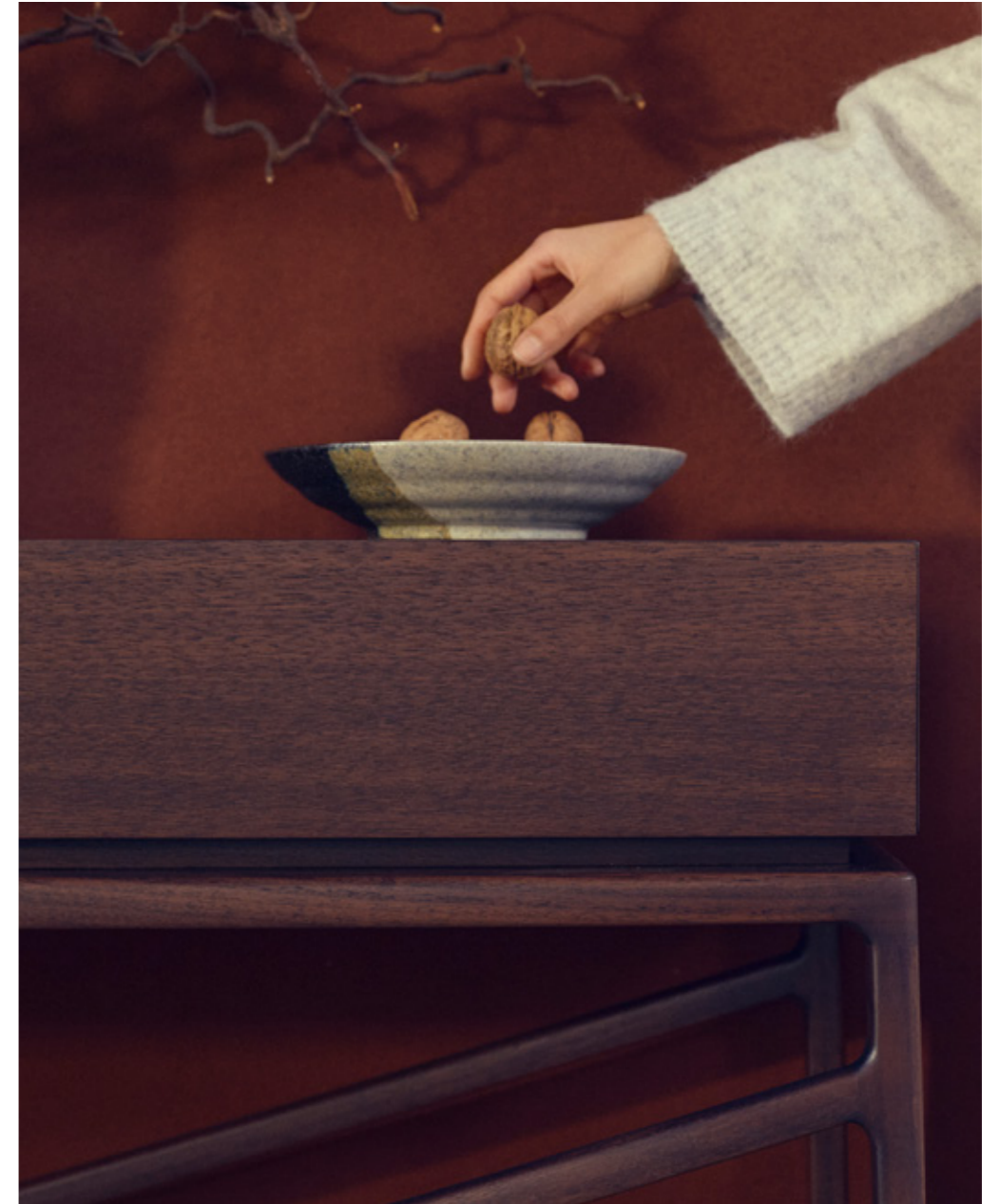



## Teahouse Cabinet



A small, compact cabinet designed to elegantly hold the essential items for the tea ceremony. The base, crafted from solid American walnut, supports a container made of plywood veneered with American walnut, featuring hinged doors equipped with burnished solid brass hinges. The lower section of the interior is organized with two drawers and a pull-out tray, while the upper section includes a shelf divided into three compartments. The internal doors are equipped with four low boxes, two medium boxes and four high boxes with caps, fixed with magnets.

AVAILABLE IN AMERICAN WALNUT IN THE FINISHES NATURAL, DARK, MOKA, OR BROWN.

Piccolo cabinet dalle dimensioni compatte, progettato per custodire con eleganza gli oggetti essenziali alla cerimonia del tè. Il basamento in legno massello di noce americano sorregge un contenitore in multistrato impiallacciato noce americano, con ante a battente dotate di cerniere in ottone massiccio brunito. L'interno è organizzato nella parte bassa, con due cassetti e un vassoio estraibile, mentre nella parte alta con una mensola suddivisa in tre scomparti. Le ante interne sono equipaggiate con quattro scatole basse, due scatole medie e quattro scatole alte con tappo, tutte fissate tramite calamita.

DISPONIBILE IN NOCE AMERICANO NELLE FINITURE NATURALE, DARK, MOKA O BROWN.

DIMENSIONS  
DIMENSIONI

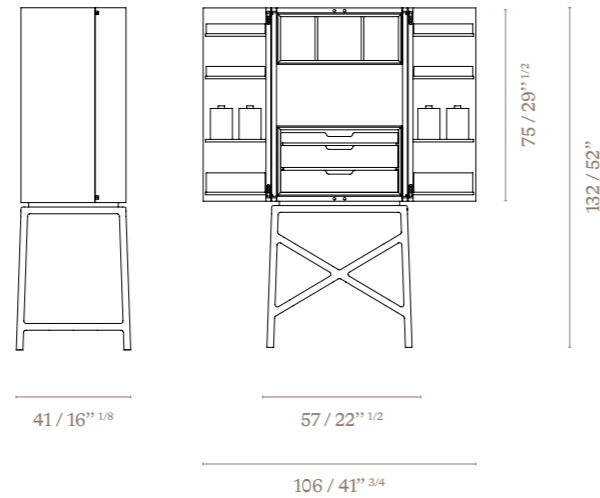

## Teahouse Console

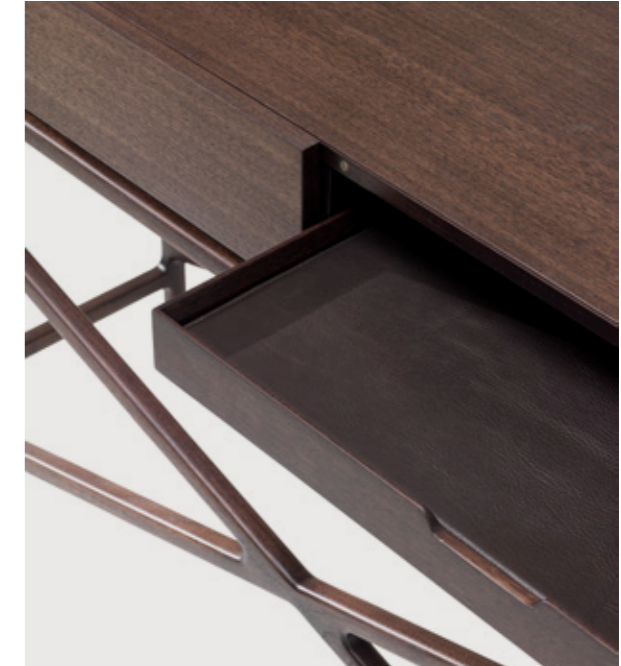

An elegant console designed for keeping essential items with sophistication. The structure rests on a base made of solid American walnut, supporting a horizontal container with two retractable drop-down doors, crafted from poplar plywood veneered with American walnut and fitted with burnished solid brass hinges. Inside, each compartment features a drawer with beveled edges that slides out on guides, which can be equipped with a soft leather mat finished with a refined tone-on-tone perimeter stitch.

AVAILABLE IN AMERICAN WALNUT IN THE FINISHES NATURAL, DARK, MOKA, OR BROWN.

Elegante consolle progettata per custodire con raffinatezza gli oggetti essenziali. La struttura poggia su un basamento in legno massello di noce americano, sostenendo un contenitore orizzontale con due ante a ribalta a scomparsa realizzato in multistrato di pioppo impiallacciato noce americano, fissate con cerniere in ottone massiccio brunito. All'interno, ogni vano ospita un cassetto con sponde smussate, estraibile tramite guide, che può essere dotato di un morbido tappetino in pelle, rifinito con una preziosa cucitura perimetrale tono su tono.

DISPONIBILE IN NOCE AMERICANO NELLE FINITURE NATURALE, DARK, MOKA O BROWN.

DIMENSIONS  
DIMENSIONI

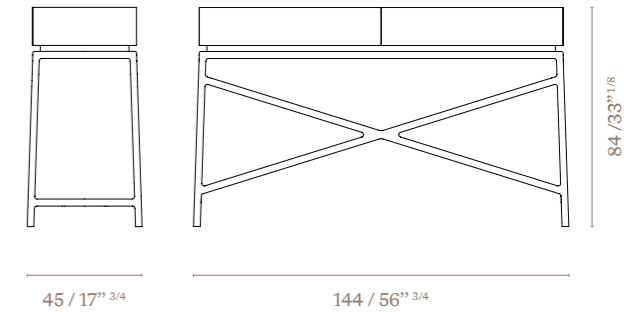



## Teahouse Chair



A low-seated armchair designed to provide a welcoming and relaxed experience.

The frame, crafted from solid American walnut, supports a seat platform made of poplar plywood veneered with American walnut. The cushions are secured to the frame with elegant leather straps, fastened by solid brass cufflinks. Simple and refined, the design highlights every structural element, each detail meticulously finished to the highest standard.

AVAILABLE IN AMERICAN WALNUT IN THE FINISHES NATURAL, DARK, MOKA, OR BROWN, WITH UPHOLSTERY IN LEATHER SUPERIOR.

Poltroncina dalla seduta bassa, pensata per offrire un'esperienza accogliente e rilassata. La struttura, realizzata in legno massello di noce americano, accoglie un pianale di seduta in multistrato di pioppo impiallacciato noce americano. I cuscini sono fissati alla struttura tramite eleganti tracolle in pelle, ancorate con gemelli in ottone massiccio brunito. Essenziale e raffinata, mette in risalto ogni elemento costruttivo, rifinito con la massima cura nei dettagli.

DISPONIBILE IN NOCE AMERICANO NELLE FINITURE NATURALE, DARK, MOKA O BROWN CON RIVESTIMENTO IN PELLE NATURALE.

### DIMENSIONS DIMENSIONI

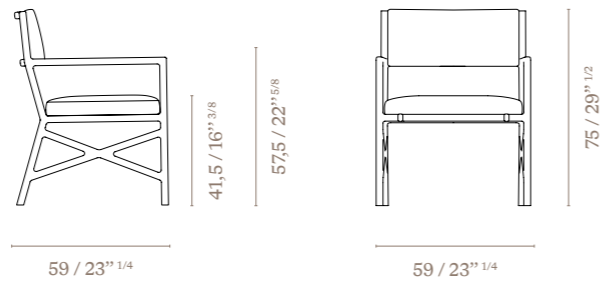

A table with a linear shape and minimalist style, defined by its unique proportions: narrow and low, it offers greater freedom of arm movement and a more comfortable, relaxed posture. The structure features a four-legged trestle with a central crossbar, crafted from solid American walnut. The top, made of poplar plywood veneered with American walnut, is slightly elevated above the frame and finished with a beveled edge that further lightens its visual presence.

AVAILABLE IN AMERICAN WALNUT IN THE FINISHES NATURAL, DARK, MOKA, OR BROWN.

Tavolo dalla forma lineare e dallo stile minimale, caratterizzato da proporzioni insolite: stretto e basso, favorisce una maggiore libertà di movimento delle braccia e una postura più confortevole e rilassata. La struttura è composta da un cavalletto a quattro gambe con crociera centrale, realizzato in legno massello di noce americano. Il piano, in multistrato di pioppo impiallacciato noce americano, è leggermente sollevato rispetto alla struttura e rifinito sul bordo con uno smusso che ne alleggerisce ulteriormente la percezione visiva.

DISPONIBILE IN NOCE AMERICANO NELLE FINITURE NATURALE, DARK, MOKA O BROWN.

### DIMENSIONS DIMENSIONI

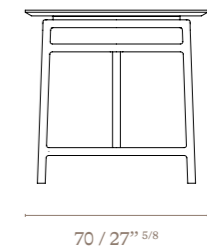
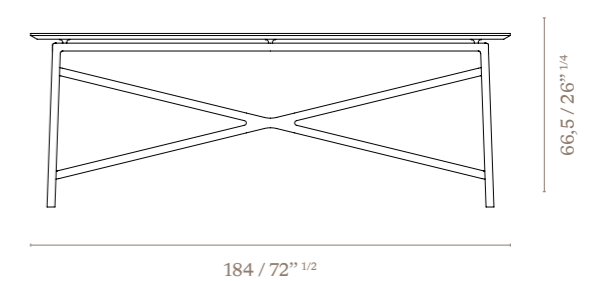



Ceccotti Collezioni Srl  
+39 050 8067550  
info@ceccotticollezioni.it  
www.ceccotticollezioni.it

*Teahouse* Catalogue  
April 2025  
© Ceccotti Collezioni Srl

Ceccotti Collezioni Srl reserves  
the right to make any necessary  
modifications and improvements to  
the products in these depictions, at any  
time and without prior notification.

<sup>IT</sup> Ceccotti Collezioni Srl si riserva  
il diritto di apportare le modifiche  
necessarie e migliorative ai prodotti  
qui illustrati, in qualsiasi momento e  
senza obbligo di preavviso.

Graphics and Art Direction  
STUDIO NUVOLE

Location photography  
MATTIA PARODI

Still life photography  
MARIO CIAMPI

Set Styling  
ELENA MORA

Printing  
AZZERBONI PRINTING SRL



